

# Computer Main Board defect Post Card

## Operating Instructions

(there are editions in Chinese for you to choose)

- The globally unique Main board Run Indicative Light that is new is on it;
- It's the SMD device that do no harm to hands;
- The manual is updated and you can choose it in English or in Chinese;
- It's the function that a sound remind you there is a trouble;
- The card can insert in either PCI slot or ISA slot;
- It do no harm to the devise while you insert the card wrongly and make it functioned.
- It can display the cause code even though the computer stop running in the state of black screen.
- It can test important signals of the Main board even without CPU when it's on power.

The number of patent: 01224987.4

The number of certificate: 513427

Infringement must be investigated

Developed by Hua Tong electrical company of Guangzhou  
Province in China

Email: P678@163.net

### Introduce of the run LED

The run LED makes use of only a few components and circuit and needs a few signals of the main board's slot. The probability of the trouble with the run LED is very small. Even though you plug the card in the bad slot, the card dose not indicate the error code, even to the extent that All lights is off except that the run light can be quite possible to run normally. You can solve the following problems by the result of "If the run LED had sparkled the main board had even run ."

1. The part of the codes of the card is bad;
2. The card is not compatible with the main board which you are using;
3. PCI slot or ISA slot is bad;
4. The card's interface cannot match the slot well by the cause of the card 's plugging incorrectly, the dirty of the interface, the rusty slot and so on.
5. The main board may stop running;
6. The main board is running with programs which is out of relation to the codes;

### Distinguish true and false

The PI0050 is more compatible than the economical and really useful PI0049 with main board of superior quality such as PIII、PIV and so on. So you can distinguish the PI0049 regarded as PI0050 by their characteristics as follows, and also you can dial this number 086 139 2517 4332 or write to me by E-mail:[p678@163.net](mailto:p678@163.net) to the get lastest distinguishing messages.

TRUE

- There is "China Copyright 01224987.4"on the edge of PCB;
- There is "China Copyright 513427"on PI0049、pi0050;
- On the back of the card ,there is a telephone number of "086 139 2517 4332;

FLASE

The characteristics of spurious cards that have been known:

- "中国专有号: 01223987.3"
- "专有技术: 01224988.3"
- "专利号: 02125087.5"(It is the patent of biology organic compound)
- Be careful ! The spurious cards always are made of bad or unsuitable materials. It hasn't

been tested by the professional equipment and has no simulation technique.

- At the same time, there may be a few I0049 card regarded as the PI0050 card to sell.

## Catalogue

1.Synopsis.....	.....
2.Obligatory contents.....	.....
3.Hexadecimal character table.....	.....
4.Description of LED displays.....	.....
6.Flow chart.....	.....
7.Error codes table.....	.....
8.Description of beep code.....	.....
(1)    AMI BIOS beep codes (fatal error).....	.....
(2)    AMI BIOS beep codes (Non-fatal error).....	.....
(3)    Award BIOS beep codes .....	.....
(4)    Phoenix BIOS beep codes.....	.....
(5)    IBM BIOS beep codes.....	.....
9.Corrective Action.....	.....
(1)    If I forget the password, what can I do?.....	.....
①Omnipotent password.....	.....
a. AMI password.....	.....
b. Award password.....	.....
c. Other ways.....	.....
②Discharge by software.....	.....
③Discharge by hardware.....	.....
④.Other way.....	.....
(2)    How to enter CMOS SETUP?.....	.....
10.Answers of frequently-asked questions.....	.....
11.If the code is not included in the book, what can I do?.....	.....

### 1.SYNOPSIS

The card is named POST (Power On Self Test ) card too, it could display the error code by the result of POST ,then you would soon determine cause of the error by error codes table. Especially when the PC can't boot operating system, or it is a black screen, or the card and motherboard couldn't issue an audible beep. It is a powerful diagnostic tool. Now just use it, you'll get twice the result with half the effort.

When the power is turned on, the BIOS first would have a strict test with system circuit、memory、 keyboard、 video、 hard disc、 floppy drive and so on. It analyzes the system configuration and initializes the basic I/O setup. At last when all is normal, it boots the operating system. The obvious feature of testing crucial components is demarcate by curse's appearing .At first, the BIOS tests the crucial components .If the testing is abnormal, the computer stopped compulsively; The curse cannot appear in the screen; There is no response to the screen. The BIOS tests common components afterwards .If the testing is abnormal, the computer continues to run and displays the information of error. When there is some trouble with the computer and the testing is abnormal, especially the testing crucial component, no displaying in the screen, the black screen, you can put the Post card in the expansive slot .You will know the cause of the trouble by the code that the card indicates and the error codes table of this manual.

### 2.OBLIGATORY CONTENTS

1.The error codes table is in the order of the codes' value from small to big. The sequence in which the code displays is decided by BIOS of the motherboard.

2. You must identify that the code that POST card displayed is "initiative code" or "Error code".  
"initiative code" is meaningless.

①How do we distinguish "initiative code" or "Error code" of conventional two-bit-code POST card?

When conventional two-bit-code POST card displayed a code. At first, we must see whether there have been some other codes varying before the code is displayed. If there have been some codes varying and it stops at a certain code in the end, the code is the "error code"; If the displayed code is first code and you cannot see any other code varying before it, the code is the "initiative code". The "initiative code" is meaningless. But sometimes the speed of much code varying is too fast so that by unaided eye we cannot make a judgement whether there have been some other codes varying before it stops at the certain code that I can see in the end. You need consider this code as the "Error code" here in this condition. If you have not solve the trouble, this code must be the "initiative code".

As long as code "0000" or "FFFF" is displayed by four-bit-code POST card, the code "0000" or "FFFF" is "initiative code". It is no need for you to make a judgment by unaided eye whether there have been some other codes varying before it stops at the code "0000" or "FFFF".

②Why is the "initiative code" meaningless?

The first code that is displayed when power is on is named "initiative code" by us, because the debug card is also electrical device itself. When the power is on, the card will display one two-bit code automatically. It is the initiative code. But the code is not the POST code (referred to the "SYNOPSIS" in the chapter one of the manual) of the computer. So the "initiative code" is meaningless.

3. The codes that haven't been defined is not included in the table.

4. For the different BIOS (such as AMI、Award、Phoenix ), the code is meaning differently . So you must make sure that which kind of BIOS you are testing by viewing the users' guide、Seeing symbol on the BIOS IC of the motherboard or seeing the screen directly while the computer booting

5. There is no more than some code displayed when you insert the card into the PCI slot on a few brands of motherboards, but when you plug it into the ISA slot, all the code can be displayed. At present, it has be discovered that all codes is displayed when you insert the card into the PCI slot of several brands of computers which not all codes is displayed when you plug the card in the ISA slot. So we suggest that you need plug the card from one slot to another slot when consulting the code is unsuccessful. In addition, the different slot on the certain motherboard in the different states. For example, all codes can be displayed from "00" to "FF" when you plug the card in the PCI slot that is near the CPU on the motherboard DELL810 while only a part of codes can be displayed from "00" to"38" when you plug the card in the other PCI slot on the motherboard DELL810.

6. The time of PCI that the resetting signal needs is not always synchronized with the time of ISA .So sometimes the code begin to be displayed when the card in the ISA, but the resetting light of PCI has not been off while the card stops to display the original code.

7. As there are more and more different kinds and structures of the motherboard, and the codes of BIOS POST is updated constantly, so the cause of trouble that error code indicates is just a reference for you.

8. According to experience, the card of two-bit code is reliable if you plug it in the slot on the motherboard below and including the P II 300. It will stop running or it dose not indicate the error code or it indicates false error code. As until recently we haven't received the bad reflect about the four-bit code card of P0050. We suggest you buy and use the four-bit code card of

## 3.Hexadecimal character table

Decimalism	0	1	2	3	4	5	6	7	8	9	10	11	12	13	14	15
Hexadecimal	0	1	2	3	4	5	6	7	8	9	A	B	C	D	E	F
Display	0	1	2	3	4	5	6	7	8	9	A	B	C	D	E	F

## 5.Description of LED displays

LED	Signal Type	Description
RUN	Bus pulse	If the LED sparkles, the main board has been running. If the man board hasn't run, the LED is off.
CLK	Bus clock	As long as the main board is on power after you plug the card in either PCI slot or ISA slot, the LED is on. or else there is no bus clock signal.
BIOS	Base input/output signals	As long as the CPU is reading to BIOS when the board is on powered, the LED sparkles.
IRDY	Main equipments is ready	The LED sparkles when there is a IRDY signal.
OSC	Oscillation signal	It is oscillation signal of ISA slot. The LED should be on, As long as the Power is on after you plug the card in the ISA slot on the main board. Or else the crystal oscillation circuit is broken, and there is no OSC signal.
FRAME	Frame periods	It is cycle frame signal of PCI slot. The LED should be on, As long as the Power is on after you plug the card in the PCI slot on the main board. The LED sparkles when the FRAME signal is coming. Or else there is no FRAME signal. Lights all the time.
RST	Resetting signal	The LED ought to have been on for half second since you press the power switch or the reset switch. If it is on all the time, please check whether the resetting pin connects to the accelerating switch or makes up a short circuit or there is some trouble with the resetting circuit.
12V	Power	The LED should be on, As long as the Power is on after you plug the card in the slot. Or else there is no voltage of 12V or there is short circuit.

-12V	Power	The LED should be on, As long as the Power is on after you plug the card in the slot. Or else there is no voltage of-12V or there is short circuit.
5V	Power	The LED should be on, As long as the Power is on after you plug the card in the slot. Or else there is no voltage of 5V or there is short circuit.
-5V	Power	The LED should be on, As long as the Power is on after you plug the card in the ISA slot. Or else there is no voltage of-5V or there is short circuit. (There is own -5V of ISA slot.)
3V3	Power	There is the proper voltage of 3V3 of the PCI volt. The LED should be on, As long as the Power is on after you plug the card in the PCI slot, but sometimes the LED may be off by the reason that there is no voltage of 3V3 of a few PCI slot or there is open circuit.

### 6.Flow chart

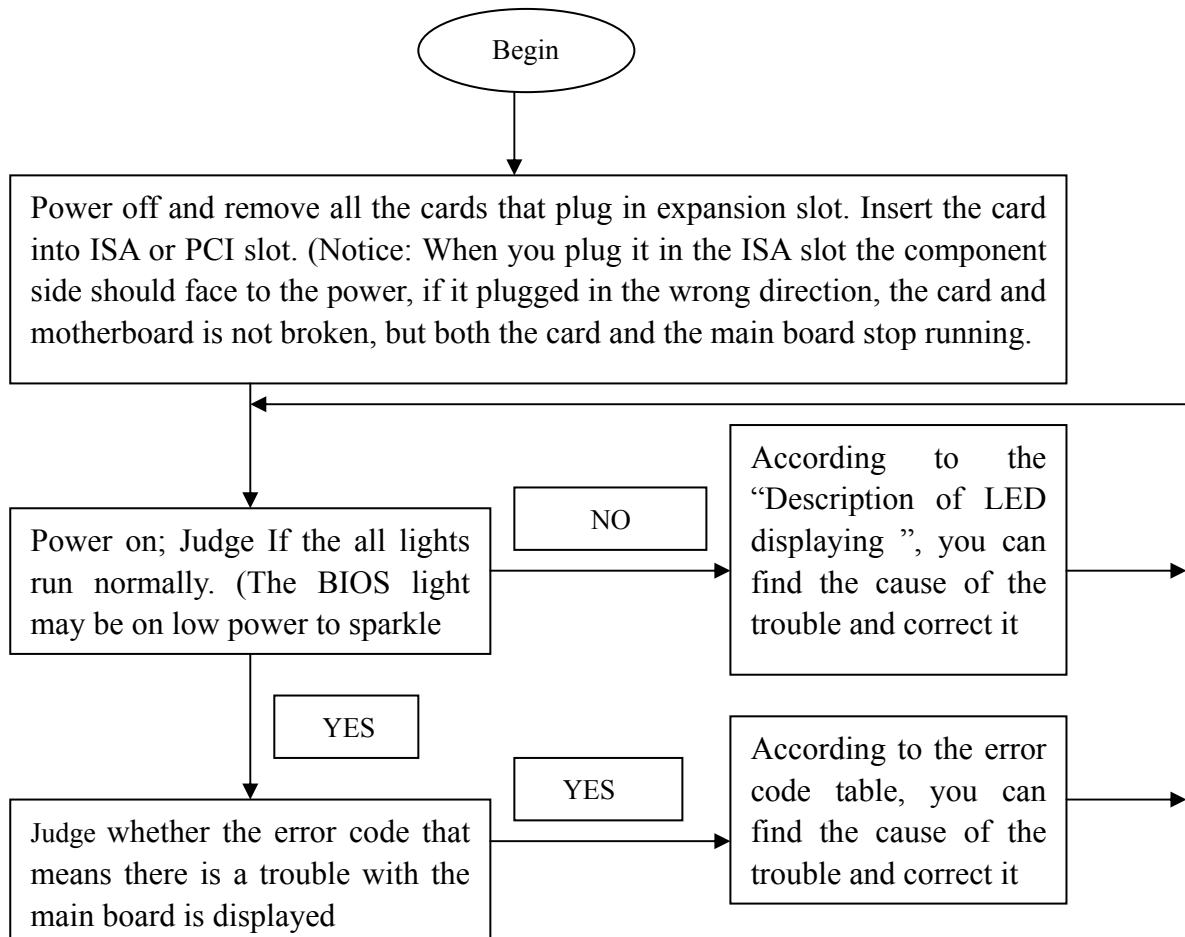

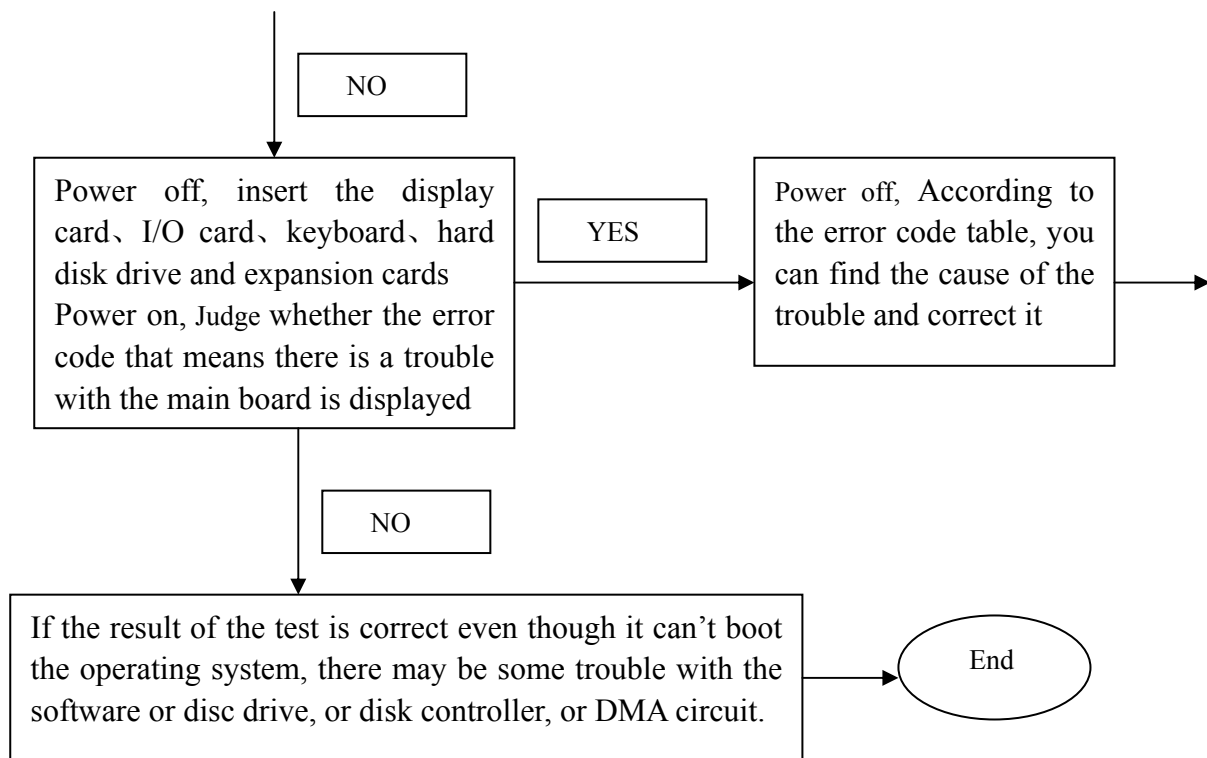

7.Error code table

CODE	Award	AMI	Phoenix4.0/Tandy3000
00		Copying code to specific area is done. Passing control to INT 19h boots loader next.	
01	Processor Test 1 verifies Processor status (1FLAGS) . Test the following processor status flags: carry, zero, sign, overflow.		CPU is testing the register inside or the test fails, please check the CPU or replace it.
	The BIOS sets each flags and verifies whether they are set. After then It turns each flag off and verifies whether it is off.		
02	Test All CPU Registers Except SS, SP, and BP with Data FF and 00		Verify Real Mode
03	Disable NMI, PIE, AIE, UEI, SQWV.	The NMI is disabled. Next, It checks a soft reset or the power condition	Disable Non maskable Interrupt (NMI)
	Disable video, parity checking, DMA.		
	Reset math coprocessor.		
	Clear all page registers, CMOS shutdown byte.		

	Initialize timer 0, 1, and 2, including set EISA timer to a known state.		
	Initialize DMA controllers 0 and 1.		
	Initialize interrupt controllers 0 and 1.		
	Initialize EISA extended registers.		
04	RAM must be periodically refreshed to keep the memory from decaying. This refreshing function is working properly.		Get CPU type
05	Keyboard Controller Initialization	The BIOS stack has been built. Next, it disable cache memory.	DMA initialization is in progress or fails
CODE	Award	AMI	Phoenix4.0/Tandy3000
06	Reserved	Uncompressing the POST code next.	Initialize system hardware
07	Verifies whether CMOS is Working correctly, Detects whether battery is bad	Initialize the CPU and the CPU data area subsequently.	Disable shadow and execute code from the ROM.
08	Early chip set initialization	The CMOS checksum is computed.	Initialize chipset with initial POST values
	Memory presence test		
	OEM chip set routines		
	Clear low 64K memory		
	Test first 64K memory		
09	Initialize Cyrix CPU		Set IN POST flag
	Initialize Cache		
0A	Initialize first 120 interrupt vectors with SPURIOUS-INT-HDLR and initialize INT 00h-1Fh according to INT-TBL.	The CMOS checksum calculation is done. Initialize the CMOS status register for date and time next.	Initialize CPU registers



0B	Test CMOS RAM Checksum, if it is bad, or INS Key is Pressed, Load the default	The CMOS status register is initialized. Next, performing any required initialization before the keyboard BAT command is issued	Enable CPU cache
0C	Detect Type of Keyboard Controller.	The keyboard controller input buffer is free. Next, issue the BAT command to the keyboard controller.	Initialize caches to initial POST values
	Set NUM_LOCK Status		
0D	Detect CPU Clock;		
	Read CMOS location 14h to find out type of video in use.		
	Detect and initialize video adapter.		
CODE	Award	AMI	Phoenix4.0/Tandy3000
0E	Test Video Memory and write sign-on information to screen.	The keyboard controller BAT command result has been verified. Next, perform any necessary initialization after the keyboard controller BAT command test	Initialize I/O component
	Setup shadow RAM? Enable shadow according to setup.		
0F	Test DMA Cont. 0; BIOS Checksum Test.	The initialization after the keyboard controller BAT command test is done. The keyboard command byte is written next.	Initialize the local IDE bus.
	Detect and Initialize Keyboard.		
10	Test DMA Controller 1	The keyboard controller command byte is written. Next, issue the Pin 23 and 24 blocking and unblocking command	Initialize Power Management

11	Test DMA Page Registers	Next, check if <End> or <Ins> keys were pressed during power on. Initializing CMOS RAM if the Initialization CMOS RAM in every boot AMIBIOS POST option was set in AMIBCP or the <End> key was pressed.	Load alternate registers with initial POST values
12	Reserved	Next, disabling DMA controllers 1 and 2 and interrupt controllers 1 and 2	Restore CPU control word during warm boot
13	Reserved	The video display has been disabled. Port B has been initialized. Next, initialize the chipset.	Initialize PCI Bus primary devices
CODE	Award	AMI	Phoenix4.0/Tandy3000
14	Test 8254 Timer 0 Counter 2	The 8254 timer test will begin next.	Initialize keyboard controller
15	Verify 8259 Channel 1 Interrupts by Turning Off and On the Interrupt Lina		
16	Verify 8259 Channel 2 Interrupts by Turning Off and On the Interrupt Lina		BIOS ROM checksum
17	Turn Off Interrupts and verify whether Non maskable Interrupt Register is On		Initialize cache before memory Auto size
18	Force an Interrupt and Verify the Interrupt Occurring.		Initialize 8254 timer.
19	Test Stuck NMI Bits; Verify whether NMI Can Be Cleared	The 8254 timer test is over. Starting. The memory refresh test is after that	
1A	Display CPU clock	The memory refreshing lina is triggered. Check the	Initialize 8237 DMA controller

		15 microsecond on/off time next	
1B	Reserved		
1C	Reserved		Reset Programmable Interrupt Controller
1D	Reserved		
1E	Reserved		
1F	If EISA non-volatile memory checksum is normal, execute EISA initialization. If not, execute ISA tests and clear EISA mode flag. Test EISA configuration memory integrity (checksum & communication interface).		
20	Initialize Slot 0 (System Board)		Test whether DRAM refreshes.
21	Initialize Slot 1		
22	Initialize Slot 2		Test 8742 Keyboard Controller
CODE	Award	AMI	Phoenix4.0/Tandy3000
23	Initialize Slot 3	Read the 8042 input port and disable the MEGAKEY Green PC feature next. Make the BIOS code segment rewrite and perform any necessary configuration before initializing the interrupt vectors	
24	Initialize Slot 4	The configuration is required before interrupt vector initialization has completed. Interrupt vector initialization is about to begin	Set ES segment register to 4 GB
25	Initialize Slot 5	Interrupt vector initialization is done. Clearing the password if the POST DIAG	

		switch is on.	
26	<p>1.test the exception situation of protected mode. Please check the memory of CPU and main board.</p> <p>2.no fatal trouble, VGA displayed normally. If nonfateful trouble occurred, then display error message in VGA, else Boot operating system. Now code 26 is OK code, and no any other codes can be displayed.</p>	<p>1.Read /write、 input、 output port of 8042 keyboard, readyfor resolve mode, continue to get ready for initialization of all data,check the 8042 chips on main board.</p> <p>2.referred to the left .</p>	<p>1.enable A20 address line, check the A20 pins of memory controlling chips, and check circuit, correlated to pins. In memory slot, may be A20 pin and memory pins are not in contact, or memory A20 pins bad.</p> <p>2.referred to the left.</p>
27	Initialize Slot 7	Any is initialized before. Setting video mode will be done next	
28	Initialize Slot 8	Initialization is done before. Setting the video mode completes. Configure the monochrome mode and color mode settings next	Auto size DRAM
29	Initialize Slot 9		Initialize POST Memory Management
2A	Initialize Slot 10	Initialize the different bus system and static output devices, if it is present	Clear 512 KB base RAM
2B	Initialize Slot 11	Passing control to the video ROM to perform any required configuration before the video ROM test.	
2C	Initialize Slot 12	All necessary processing before passing control to the video ROM is done. Look for the video ROM next and pass control to it.	RAM fails on address 1 lina XXXX*

2D	Initialize Slot 13	The video ROM has returned control to BIOS POST. Performing any required processing is after the video ROM had control.	
2E	Initialize Slot 14	Complete post-video ROM test processing. If the EGA/VGA controller is not found, perform the display memory read/write test next	RAM fails on data bits XXXX* of low byte of memory bus
2F	Initialize Slot 15	The EGA/VGA controller was not found. The display memory read/write test is about to begin	Enable cache before system BIOS shadow
30	Size of base Memory From 256K to 640K and Memory is Extended Above 1MB.	The display memory read/write test passed. Look for retracing checking next	
31	Test Base Memory From 256K to 640K and Memory Extended Above 1MB	The display memory read/write test or retracing checking failed. Perform the alternate display memory read/write test next	
32	If EISA Mode, Test EISA Memory Found in Slots Initialization	The alternate display memory read/write test passed. Look for alternate display retracing checking next.	Test CPU bus-clock frequency
33	Reserved		Initialize Phoenix Dispatch manager
34	Reserved	Video display checking is over. Set the display mode next.	
35	Reserved		
36	Reserved		Warm start and shut down

37	Reserved	The display mode is set. Displaying the information when it boots next.	
38	Reserved	Initialize the bus input, IPL and general devices next, if present	Shadow system BIOS ROM
39	Reserved	Display bus initialization error messages.	
3A	Reserved	The new cursor position has been read and saved. Display the Hit <DEL> message next	Auto size cache
3B	Reserved	The Hit <DEL> message is displayed. The protected mode memory test is about to start.	
3C	Setup Enabled		Advanced configuration of chipset registers
3D	Detect if Mouse is Present, Initialize Mouse, Install Interrupt Vectors		Load alternate registers with CMOS values
3E	Initialize Cache Controller		
3F	Reserved		
40	Display Virus Protest Disabled or Enabled	Prepare the descriptor tables next	
41	Initialize Floppy Disk Drive Controller and Any Drives		Initialize extended memory for Rom Pilot
42	Initialize Hard Drive Controller and Any Drives	The descriptor tables are prepared. Enter protected mode for the memory test next	Initialize interrupt vectors
43	Detect and Initialize Serial & Parallel Ports and Game Port	Entered protected mode. Enable interrupts for diagnostics mode next.	
44	Reserved	Interrupts is enabled if the diagnostics switch is on. Initialize data to check memory wrapping around at 0:0 next.	

45	Detect and Initialize Math Coprocessor	Data initialized. Check for memory wrapping around at 0:0 and find the total system memory size next	POST device initialization
46	Reserved	The memory wrapping around test is done. Memory size calculation has been done. Writing patterns to test memory next	Check ROM copyright notice
47	Reserved	The memory pattern has been written to extended memory. Write patterns to the base 640 KB memory next.	Initialize I20 support
48	Reserved	Patterns write in base memory. Determine the amount of memory below 1 MB next.	Check video configuration against CMOS
49	Reserved	The amount of memory below 1 MB has been found and verified. Determine the amount of memory above 1 MB memory next.	Initialize PCI bus and devices
4A Reserved	Reserved		Initialize all video adapters in system
4B	Reserved	The amount of memory above 1 MB has been found and verified. Check for a soft reset and clear the memory below 1 MB for the soft reset next. If this is a power on situation, go to checkpoint 4Eh next.	Quiet Boot start (optional)
4C	Reserved	The memory below 1 MB has been cleared	Shadow video BIOS ROM

		via a soft reset. Clear the memory above 1 MB next.	
4D	Reserved	The memory above 1 MB has been cleared via a soft reset. Save the memory size next. Go to checkpoint 52h next	
4E	Reboot if it is Manufacturing Mode; If not, Display Messages and Enter Setup	The memory test started, but not as the result of a soft reset. Displaying the first 64 KB memory size next.	Display BIOS copyright notice
4F	Ask Password Security (Optional)	The memory size display has started. The display is updated during the memory test. Perform the sequential and random memory test next	Initialize Multi Boot
50	Write All CMOS Values Back to RAM and Clear	The memory below 1 MB has been tested and initialized. Adjust the displayed memory size for relocation and shadowing next.	Display CPU type and speed
51	Enable Parity Checking. Enable NMI, Enable Cache Before Boot	The memory size display was adjusted for relocation and shadowing. Testing the memory above 1 MB next.	Initialize EISA board
52	Initialize Option ROMs from C8000h to EFFFFh or if FSCAN Enabled to F7FFFh	The memory above 1 MB has been tested and initialized. Saving the memory size information next.	Test keyboard
53	Initialize Time Value in 40h: BIOS Area	The memory size information and the CPU registers are saved. Enter real mode next.	
54		Shutdown was successful. The CPU is	Set key click if enabled



		in real mode. Disable the Gate A20 line, parity, and the NMI next	
55			Enable USB devices
57		The A20 address line, parity, and the NMI are disabled. Adjust the memory size depending on relocation and shadowing next.	
58		The memory size was adjusted for relocation and shadowing. Clear the Hit <DEL> message next	Test for unexpected interrupts
59		The Hit <DEL> message is cleared. The <WAIT...> message is displayed. Start the DMA and interrupt controller test next.	Initialize POST display service
5A			Display prompt "Press F2 to enter SETUP".
5B			Disable CPU cache
5C			Test RAM between 512KB and 640 KB
60	Setup virus protection (boot sector protection) functionality according to setup setting.	The DMA page register test passed. Perform the DMA Controller 1 base register test next.	Test extended memory
61	Try to turn on level 2 cache (if L2 cache has already turned on in post 3D, this part will be skipped)		
	Set the boot up speed according to setup setting		
	Last chance for chipset is initialized		
	Last chance for power management is initialized(reen BIOS only)		
	Show the system configuration table		

62	Setup NUM Lock Status According to Setup values	The DMA controller 1 base register test passed. Perform the DMA controller 2 base register test next	Test extended memory address lina
	Program the NUM lock, Set matic rate & typematic speed according to setup.		
63	If there is any changes in the hardware configuration. Update the ESCD information (PnP BIOS only)		
	Clear memory that have been used		
	Boot system via INT 19h		
64			Jump to UserPatch1
65		The DMA controller 2 base register test passed. Programme DMA controllers 1 and 2 next.	
66		Complete programming DMA controllers 1 and 2. Initialize the 8259 interrupt controller next.	Configure advanced cache registers
67		Complete 8259 interrupt controller initialization.	Initialize Multi Processor APIC
68			Enable external and CPU caches
69			Set up System Management Mode (SMM) area
6A			Display external L2 cache size
6B			Load custom defaults (optional)
6C			Display shadow-area

			message
6E			Display possible high address for UMB recovery
6F			
70			Display error message
71			
72			Check for configuration errors
76			Check for keyboard errors
7C			Set up hardware interrupt vectors
7D			Initialize Intelligent System Monitoring
7E			Initialize coprocessor if present.
7F		Enabling extended NMI source is in progress.	
80		The keyboard test has started. Clear the output buffer and check for stuck keys. Issue the keyboard reset command next.	Disable onboard Super I/O ports and IRQs.
81		A keyboard reset error or stuck key was found. Issue the keyboard controller interface test command next.	Late POST device initialization.
82		The keyboard controller interface test completed. Write the command byte and initialize the circular buffer next.	Detect and install external RS232 ports

83		The command byte was written and global data initialization has completed. Check for a locked key next.	Configure non-MCD IDE controllers
84		Locked key checking is over. Check whether a memory size mismatch with CMOS RAM data next.	Detect and install external parallel ports
85		The memory size check is done. Display a soft error and check for a password or by passing WINBIOS is Set up next.	Initialize PC-compatible PnP ISA devices
86		The password was checked. Perform any required programming before WINBIOS Setup next.	Re-initialize onboard I/O ports.
87		The programming before WINBIOS Setup has completed. Uncompress the WINBIOS Setup code and execute the AMIBIOS Setup or WINBIOS Setup utility next.	Configure Motherboard Configurable Devices (optional)
88		Returned from WINBIOS Setup and cleared the screen. Perform any necessary programming after WINBIOS Setup next.	Initialize BIOS Data Area
89		The programming after WINBIOS Setup has completed. Display the power on screen message next.	Enable Non-Maskable Interrupts (NMIs)

8A			Initialize Extended BIOS Data Area
8B		The first screen message has been displayed. The <WAIT...> message is displayed. Perform the PS/2 mouse check and extended BIOS data area allocation check next.	Test and initialize PS/2 mouse
8C		Programme the WINBIOS Setup options next.	Initialize floppy controller
8D		The WINBIOS Setup options are programmed. Reset the hard disk controller next.	
8E		The hard disk controller has been reset. Configure the floppy drive controller next.	
8F			Determine number of ATA drives (optional)
90			Initialize hard-disk controllers
91		The floppy drive controller has been configured. Configure the hard disk drive controller next.	Initialize local-bus hard-disk controllers
92			Jump to UserPatch2
93			Build MPTABLE for multi-processor boards
95		Initialize bus adaptor ROMs from C8000h through D8000h	Install CD ROM for boot

96		Initialize before passing control to the adaptor ROM at C800	Clear huge ES segment register
97		Initialize before the C800 adaptor ROM gains control has completed. The adaptor ROM check is next.	Fix up Multi Processor table
98		The adaptor ROM had control and has now returned control to BIOS POST. Perform any required processing after the option ROM returned control A	Search for option ROMs. One long, two short beeps on checksum fails.
99		Any initialization required after the option ROM test has completed. Configure the timer data area and printer base address next.	Check for SMART Drive (optional)
9A		Set the timer and printer base addresses. Set the RS-232 base address next.	Shadow option ROMs
9B		Returned after setting the RS-232 base address. Perform any required initialization before the Coprocessor test next.	
9C		Required initialization before the Coprocessor test is over. Initialize the Coprocessor next	Set up Power Management

9D		Coprocessor initialized. Perform any required initialization after the Coprocessor test next.	Initialize security engine (optional)
9E		Initialization after the Coprocessor test is complete. Check the extended keyboard, keyboard ID, and Num Lock key next. Issuing the keyboard ID command next	Enable hardware interrupts
9F			Determine number of ATA and SCSI drives
A0			Set time of day
A1			Check key lock
A2		Display any soft error next	
A3		The soft error display has completed. Set the keyboard typematic rate next.	
A4		The keyboard typematic rate is set. Programme the memory wait states next	Initialize typematic rate
A5		Memory wait state programming is over. Clear the screen. Enable parity and the NMI next	
A7		NMI and parity is enabled. Perform any initialization required before passing control to the adaptor ROM at E000 next.	
A8		Initialization before passing control to the adaptor ROM at E000hm is completed. Pass control to the adaptor ROM at E000h next	Erase F2 prompt

A9		Returned from adaptor ROM at E000h control. Performing any initialization required after the E000 option ROM had control next	
AA		Initialization after E000 option ROM control has completed. Display the system configuration next	Scan for F2 key stroke
AB		Uncompress the DMI data and execute DMI POST initialization next	
AC			Enter SETUP
AE			Clear boot flag
B0	If Interrupts Occurs in Protecting Mode	The system configuration is displayed.	Check for errors
B1	If non masked NMI Occurs, Display "Press F1 to Disable NMI, F2 Reboot"	Copy any code to specific areas.	Inform RomPilot about the end of POST.
B2			POST is done - prepare to boot operating system
B3			
B4			1 One short beep before boot
B5			Terminate QuietBoot (optional)
B6			Check password (optional)
B7			Initialize ACPI BIOS
B8			
B9			Prepare Boot
BA			Initialize SMBIOS
BB			Initialize PnP Option ROMs
BC			Clear parity checkers
BD			Display MultiBoot menu
BE	Program chipset registers with power on BIOS defaults		Clear screen (optional)



BF	Program the rest of the chipset's value according to setup (later setup value program)		Check virus and backup reminders
	If auto configuration is enabled, programmed the chipset with predefined values in the MODBINable Auto Table		
C0	Turn off OEM specific cache, shadow		Try to boot with INT 19
	Initialize standard devices with default values: DMA controller (8237); Programmable Interrupt Controller (8259); Programmable Interval Timer (8254); RTC chip.		
C1	OEM Specific-Test to Size On-Board Memory		Initialize POST Error Manager (PEM)
C2			Initialize error logging
C3	Test the first 256K DRAM		Initialize error display function
	Expand the compressed codes into temporary DRAM area including the compressed system BIOS & Option ROMs.		
C4			Initialize system error handler
C5	Enable OEM Specific-Early Shadow for Fast Boot		PnPnd dual CMOS (optional)
C6	External Cache Size Detection		Initialize note dock (optional)
C7			Initialize note dock late
C8			Force check (optional)
C9			Extended checksum (optional)
CA			Redirect Int 15h to enable remote keyboard
CB			Redirect Int 13h to Memory Technologies Devices such as ROM, RAM, PCMCIA, and serial disk
CC			Redirect Int 10h to enable remote serial video
CD			Re-map I/O and memory for PCMCIA

CE			Initialize digitizer and display message
D0		The NMI is disabled. Power on delay is starting. Next, the initialization code checksum will be verified.	
D1		Initialize the DMA controller and perform the keyboard controller BAT test. Start to refresh memory and enter 4 GB flat mode next.	
D2			Unknown interrupt
D3		Start memory sizing next	
D4		Return to real mode. Execute any OEM patches and set the stack next.	
D5		Pass control to the uncompressed code in shadow RAM at E000:0000h. The initialization code is copied to segment 0 and the control will be transferred to segment 0	
D6		Control is in segment 0. Next, checking if <Ctrl> <Home> was pressed and verifying the system BIOS checksum. If either <Ctrl> or <Home> was pressed or the system BIOS checksum is bad, next it will go to checkpoint code E0h. Otherwise, It goes to checkpoint code D7h.	

E0		The onboard floppy controller if available is initialized. Next, begin the base 512 KB memory test	Initialize the chipset
E1	E1 Setup - Page E1	Initialize the interrupt vector table next	Initialize the bridge
E2	E2 Setup - Page E2	Initialize the DMA and Interrupt controllers next.	Initialize the CPU
E3	E3 Setup - Page E3		Initialize system timer
E4	E4 Setup - Page E4		Initialize system I/O
E5	E5 Setup - Page E5		Check force recovery boot
E6	E6 Setup - Page E6	Enable the floppy drive controller and Timer IRQs. Enable internal cache memory.	Checksum BIOS ROM
E7	E7 Setup - Page E7		Go to BIOS
E8	E8 Setup - Page E8		Set Huge Segment
E9	E9 Setup - Page E9		Initialize Multi Processor
EA	EA Setup - Page EA		Initialize OEM special code
EB	EB Setup - Page EB		Initialize PIC and DMA
EC	EC Setup - Page EC		Initialize Memory type
ED	ED Setup - Page ED	Initialize the floppy drive.	Initialize Memory size
EE	EE Setup - Page EE	Look for a floppy diskette in drive A:. Read the first sector of the diskette	Shadow Boot Block
EF	EF Setup - Page EF	A read error occurred while it reads the floppy drive in drive A:.	System memory test
F0		Next, search for the AMIBOOT.ROM file in the root directory.	Initialize interrupt vectors
F1		The AMIBOOT.ROM file is not in the root directory	Initialize Run Time Clock

F2		Next, read and analyze the floppy diskette FAT to find the clusters occupied by the AMIBOOT.ROM file	Initialize video
F3		Next, read the AMIBOOT.ROM file, cluster by cluster.	Initialize System Management Manager
F4		The AMIBOOT.ROM file is not the correct size	Output one beep
F5		Next, disable internal cache memory.	Clear Huge Segment
F6			Boot to Mini DOS
F7			Boot to Full DOS
FB		Next, detect the type of flash ROM.	
FC		Next, erase the flash ROM.	
FD		Next, programme the flash ROM	
FF	Int 19 Boot Attempt  ▼	Flash ROM programming was successful. Next, restart the system BIOS.	

## 8.Description of beep code

### (1)AMI BIOS beep codes (fatal error)

1 beep	DRAM Refreshing Fails. Try to reseal the memory first. If the error still occurs, replace the memory with known good chips.
2 beeps	Parity Error in First 64K RAM. Try to reseal the memory first. If the error still occurs, replace the memory with known good chips.
3 beeps	Base 64K RAM Failure. Try to reseal the memory first. If the error still occurs, replace the memory with known good chips.
4 beeps	System timer fails
5 beeps	Process fails
6 beeps	Keyboard Controller 8042 - Gate A20 is Error. Try to reseal the keyboard controller chip. If the error still occurs, replace the keyboard chip. If the error persists, check parts of the system relating to the keyboard, e.g. try another keyboard, check to see if the system has a keyboard fuse
7 beeps	Processor Virtual Mode Exception Interrupt Error
8 beeps	Display Memory Read/Write Test Failure (Non-fatal). Replace the video card or

	the memory on the video card.
9 beeps	ROM BIOS Checksum (32KB at F800:0) Failed. It is not likely that this error can be corrected by reseating the chips. Consult the motherboard supplier or an AMI product distributor for replacement part(s).
10 beeps	CMOS Shutdown Register Read/Write Error
11 beeps	Cache memory error

(2). AMI BIOS beep codes (Non-fatal error)

2 short	POST Failure - One or more of the hardware tests has failed
1 long 2 short	An error was encountered in the video BIOS ROM, or a horizontal retracing failure has been encountered
1 long 3 short	Conventional/Extended memory failure
1 long 8 short	Display/Retrace test failed

(3). Award BIOS beep codes

1 short	No error during POST
2 short	Any Non-fatal error, enter CMOS SETUP to reset
1 long 1 short	RAM or motherboard error
1 long 2 short	Video Error, Cannot Initialize Screen to Display Any Information
1 long 3 short	Keyboard Controller error
1 long 9 short	Flash RAM/EPROM (which on the motherboard) error. (BIOS error)
Long beep	Memory bank is not plugged well, or broken.

(4).Phoenix BIOS beep codes

Beep Code	Description / What to Check
1-1-1-3	Verify Real Mode.
1-1-2-1	Get CPU type.
1-1-2-3	Initialize system hardware.
1-1-3-1	Initialize chipset registers with initial POST values.
1-1-3-2	Set in POST flag.
1-1-3-3	Initialize CPU registers.
1-1-4-1	Initialize cache to initial POST values.
1-1-4-3	Initialize I/O.
1-2-1-1	Initialize Power Management.
1-2-1-2	Load alternate registers with initial POST values.
1-2-1-3	Jump to UserPatch0.
1-2-2-1	Initialize keyboard controller.
1-2-2-3	BIOS ROM checksum.
1-2-3-1	8254 timer initialization.
1-2-3-3	8237 DMA controller initialization.
1-2-4-1	Reset Programmable Interrupt Controller.
1-3-1-1	Test DRAM refresh.
1-3-1-3	Test 8742 Keyboard Controller.
1-3-2-1	Set ES segment to register to 4 GB.
1-3-3-1	28 Autosize DRAM.

1-3-3-3	Clear 512K base RAM.
1-3-4-1	Test 512K base address line.
1-3-4-3	Test 512K base memory.
1-4-1-3	Test CPU bus-clock frequency.
1-4-2-4	Reinitialize the chipset.
1-4-3-1	Shadow system BIOS ROM.
1-4-3-2	Reinitialize the cache.
1-4-3-3	Autosize cache.
1-4-4-1	Configure advanced chipset registers.
1-4-4-2	Load alternate registers with CMOS values.
2-1-1-1	Set Initial CPU speed.
2-1-1-3	Initialize interrupt vectors.
2-1-2-1	Initialize BIOS interrupts.
2-1-2-3	Check ROM copyright notice.
2-1-2-4	Initialize manager for PCI Options ROMs.
2-1-3-1	Check video configuration against CMOS.
2-1-3-2	Initialize PCI bus and devices.
2-1-3-3	Initialize all video adapters in system.
2-1-4-1	Shadow video BIOS ROM.
2-1-4-3	Display copyright notice.
2-2-1-1	Display CPU type and speed.
2-2-1-3	Test keyboard.
2-2-2-1	Set key click if enabled.
2-2-2-3	56 Enable keyboard.
2-2-3-1	Test for unexpected interrupts.
2-2-3-3	Display prompt "Press F2 to enter SETUP".
2-2-4-1	Test RAM between 512 and 640k.
2-3-1-1	Test expanded memory.
2-3-1-3	Test extended memory address line.
2-3-2-1	Jump to UserPatch1.
2-3-2-3	Configure advanced cache registers.
2-3-3-1	Enable external and CPU caches.
2-3-3-3	Display external cache size.
2-3-4-1	Display shadow message.
2-3-4-3	Display non-disposable segments.
2-4-1-1	Display error messages.
2-4-1-3	Check for configuration errors.
2-4-2-1	Test real-time clock.
2-4-2-3	Check for keyboard errors
2-4-4-1	Set up hardware interrupt vectors.
2-4-4-3	Test coprocessor if present.
3-1-1-1	Disable onboard I/O ports.
3-1-1-3	Detect and install external RS232 ports.
3-1-2-1	Detect and install external parallel ports.

3-1-2-3	Re-initialize onboard I/O ports.
3-1-3-1	Initialize BIOS Data Area.
3-1-3-3	Initialize Extended BIOS Data Area.
3-1-4-1	Initialize floppy controller.
3-2-1-1	Initialize hard-disk controller.
3-2-1-2	Initialize local-bus hard-disk controller.
3-2-1-3	Jump to UserPatch2.
3-2-2-1	Disable A20 address line.
3-2-2-3	Clear huge ES segment register.
3-2-3-1	Search for option ROMs.
3-2-3-3	Shadow option ROMs.
3-2-4-1	Set up Power Management.
3-2-4-3	Enable hardware interrupts.
3-3-1-1	Set time of day.
3-3-1-3	Check key lock.
3-3-3-1	Erase F2 prompt.
3-3-3-3	Scan for F2 key stroke.
3-3-4-1	Enter SETUP.
3-3-4-3	Clear in-POST flag.
3-4-1-1	Check for errors
3-4-1-3	POST done--prepare to boot operating system.
3-4-2-1	One beep.
3-4-2-3	Check password (optional).
3-4-3-1	Clear global descriptor table.
3-4-4-1	Clear parity checkers.
3-4-4-3	Clear screen (optional).
3-4-4-4	Check virus and backup reminders.
4-1-1-1	Try to boot with INT 19.
4-2-1-1	Interrupt handler error.
4-2-1-3	Unknown interrupt error.
4-2-2-1	Pending interrupt error.
4-2-2-3	Initialize option ROM error.
4-2-3-1	Shutdown error.
4-2-3-3	Extended Block Move.
4-2-4-1	Shutdown 10 error.
4-3-1-3	Initialize the chipset.
4-3-1-4	Initialize refresh counter.
4-3-2-1	Check for Forced Flash.
4-3-2-2	Check HW status of ROM.
4-3-2-3	BIOS ROM is OK.
4-3-2-4	Do a complete RAM test.
4-3-3-1	Do OEM initialization.
4-3-3-2	Initialize interrupt controller.
4-3-3-3	Read in bootstrap code.

4-3-3-4	Initialize all vectors.
4-3-4-1	Boot the Flash program.
4-3-4-2	Initialize the boot device.
4-3-4-3	Boot code was read OK.

(5). IBM BIOS beep codes

Beep Code	Description
No Beeps	No Power, Loose Card, or Short.
1 Short Beep	Normal POST, computer is ok.
2 Short Beep	POST error, review screen for error code.
Continuous Beep	No Power, Loose Card, or Short.
Repeating Short Beep	No Power, Loose Card, or Short.
One Long and one Short Beep	Motherboard issue.
One Long and Two short Beeps	Video (Mono/CGA Display Circuitry) issue.
One Long and Three Short Beeps.	Video (EGA) Display Circuitry.
Three Long Beeps	Keyboard / Keyboard card error.
One Beep, Black or Incorrect Display	Video Display Circuitry.

9. Corrective Action

(1). If I forget the password, what can I do?

If you forget your password, don't worry! The following will help you:

①. Omnipotent password

For the BIOS from different manufacturer, their password is different too. Both omnipotent password and password that users set are able to unlock the computer. Try the abbreviation of manufacturer or the character string which formed by the first letter of each word. May be it is the omnipotent password, for example:

I. AMI password

AMI	AMI	Bios310	AMI!SW	KILLCMOS
A. M. I	589589	SMOSPWD	AMISSETUP	ami.kez
BIOS	ammii	AMI_SW	ami?	AMI.KEY
AMI SW	amipswd	amidecod	amiami	
PASSWORD	LKWPETER	BIOSPASS	AMIPSWD	

II. Award passwod

PASSWORD	HLT	biostar	?award	djonet
AWARD SW	ALFAROME	j09F	1EAAh	g6PJ
AWARD?SW	256256	j256	admin	HELGA-S
AWARE_PW	589721	LKWPETER	ally	HLT
award_ps	Alfarome	ally	award	zjaaadc
AWARD?SW	APAf	J322	award.sw	J64
SWITCHED_SW	1kwpeter	SER	award_?	1kw peter
TTPTHA	awkward	SKY_FOX	zbaaaca	setup
1kwpeter	AWARD_SW	Sxyz	Syxz	SZYX
biostar	BIOS	t0ch20x	BIOSTAR	t0ch88
01322222	CONCAT	TzqF	CONCAT	ttptha
589589	CONDO	ZAAADA	Awkward	wodj



### III.others

Phoenix BIOS: phoenix	Megastar: star
Biostar Biostar: Q54arwms	Micron: sldkj754xyzall
Compag: compag	Micronies: dn 04rie
Concord:last	Nimble: xdfk9874t3
CTX International: CTX_123	Packard Bell: bell9
CyberMax: congress	QDI: QDI
Daewoo: Daewuu	Quantex: textl xljlbj
Daytek: Daytec	Research: Co12ogro2
Dell: Dell	Shuttle: spacve
Digital Equipment: komprie	Siemnts Nixdorf: SKY_FOX
Enox: central	SpeedEasy: lesarotl
Freetech: Posterie	SuperMicro: ksdjfg934t
HP Vectra:hewlpack	Tinys:tiny
IBM: IBM MBIUO sertafu	TMC: BIGO
Iwill: iwill	Toshiba: 24Banc81 Toshiba toshy99
JetWay: spooml	Vextrec Technology: vextrex
Joss Technology: 57gbz6technolgi	Vobis: merlin
M Technology: mMmM	WIMBIOSnbsp BIOS v2.10: complert
MachSpeed: sp99dd	Zenith: 3098z Zenith
Magic-pro: prost	ZEOS: zeosx

#### ②.Discharge by software

CMOS ROM can be discharged by software way. Then help you to solve the password problem. Follow these method, use the prompt “DEBUG”, all things to be easy.

##### I. clear Award password

C: \>DEBUG

```

- o 70 34 ↓ or - o 70 11 ↓
- o 71 34 ↓ - o 71 ff ↓
- q ↓ - q ↓

```

##### II. clear AMI BIOS password

C: \>DEBUG

```

- o 70 16 ↓ or - o 70 10 ↓
- o 71 16 ↓ - o 71 0 ↓
- q ↓ - q ↓

```

Note: the setup of CMOS BIOS will be erased during the discharge, so the computer is able to running until you reset it. If it is COMPAQ computer, you'd better get a floppy disk which save CMOS program first, then do the discharge, or else it is easy to discharge but hard to recover.

#### ③. hardware jumper discharge to CMOS BIOS

All the computers could discharge to CMOS BIOS by switch or jumper, and clear any prompt (system booting prompt, CMOS setup prompt, key lock prompt). There are examples for the particularity of CMOS of some Original packaging computer:

The discharge of COMPAQ and AST is finished by close/open the switch, but except the state power off, follow these steps:

- a. After the external power is turned off, push SW1 and SW1-2 to “on”.

- b. External power is turned on. Restart the computer.
- c. Wait for 1 to 5 minutes, turn off the computer.
- d. Push SW1 and SW1-2 to “off”
- e. Turn on the computer, enter CMOS setup to reset it.

Most of motherboard discharge to CMOS by jumper, and for the different board, the pin is different. During the discharge, read the user’s guide of motherboard first, if the state of CMOS discharge jumper pin is not included in it, to check that whether there are signs on the motherboard, such as “Exit Batter”, “Clean CMOS”, “CMOS ROM Reset”. If you find these sign, connect the pin of switch, or else, remove the battery.

④.get helps from your dealer

If the problem is not solved still, please get in touch with you dealer.

(2). How to enter CMOS SETUP?

BIOS	Key	Screen instruction
AMI	<Del> or <ESC>	Displayed
Award	<Del> or <Ctrl>+<Alt>+<ESC>	Displayed
MR	<Del> or <Ctrl>+<Alt>+<ESC>	NONE
Quadtel	<F2>	Displayed
COMPAQ	Press<F10> when the cursor displayed on top right screen	NONE
AST	<Del>+<Alt>+<S>	NONE
Phoenix	<Del>+ <Alt>+<S>	NONE
Hewlett Packard(HP)	<F2>	NONE

10. Answers of frequently-asked questions

NOTE: 1. Don’t against the rules in motherboard quality guaranty during repair the board.

2. Resolve the trouble only when the power is off.

Error	description	solutions
Memory bank	Memory bank is bad	Replace it and try again
	Pin of memory bank is dirty	Clean it with student eraser and try again.
	It is not match the other bank.	Insert the right memory bank.
	Plugged in the wrong direction	Insert it properly
Memory slot or extended slot	The slot is dirty or something in it	Clean it
	Metallic spring slice in the slot is out of shape or ruptured.	Refit it’s shape or replace it.
	Metallic spring slice in the slot is rusty or mildewy.	Wash with the pure alcohol, Inserts it and pull it out frequently after it is dry.
CPU	CPU is bad	Replace it. (touch it to check if it does generate heat or overheated)
	The jumper setup or CMOS setup of CPU is error.	Check the setup of working voltage and frequency of CPU
	CPU pin is dirty	Clear the dirty things, insert and pull out it frequently.
	CPU is not plugged well.	Check the CPU pin



