



FARM TRAILERS, WAGONS AND RACKS

630.4
C212
P 830
1966
c.3

Contents

	PAGE
Introduction.	3
Selection of Tires for Wagons and Trailers.	3
Half Ton Trailers or Carts.	5
Trailer with Removable Side Racks.	5
Trailer or Cart With Solid Wall Box and Removable Tail Board.	6
Wide Axle Trailer.	7
Transport Wagon.	8
Two-wheel Tractor Trailer.	11
Rubber Tired Farm Wagons.	13
Combination Wagon Rack with Steel Frame.	14
Wisconsin Wagon Rack.	16
Chopped Hay Box for Combination Rack.	18
Canvas Wagon Unloader.	19
Speed Reduction Unit for Canvas Unloader.	21

FARM TRAILERS...wagons and racks

Engineering Research Service, Research Branch
Central Experimental Farm, Ottawa

Introduction

Where rubber tired tractors are used on the farm, rubber tired vehicles are desirable for farm hauling operations. With the introduction of tractors having speeds of 10 to 15 miles per hour, vehicles with rubber tires can be used in both hauling operations on the farm and in moving produce to market. The draft or pull required is less for rubber tired vehicles than for steel wheeled wagons and as racks are usually much lower on rubber tired vehicles they are easier to load than high wheel wagons.

Some of the vehicles illustrated in this publication are designed for specialized farm work, while others are suitable for many types of hauling operations. The racks can be used on home-made wagons or on commercial rubber tired farm wagons. Various other types of commercial wagons, trailers and racks suitable for farm use are now on the market.

In hauling operations on public roads and highways every precaution should be taken to prevent accidents. All highway regulations should be adhered to and the tractor and vehicle should be under complete control at all times. Light tractors with heavily loaded wagons should be operated at moderate speeds and in a low gear when going down hills. It is important that the brakes on tractors be locked together or applied evenly and with caution when hauling a loaded wagon or trailer. Licenses are required for trailers used on highways.

Selection of Tires for Wagons and Trailers

In constructing a wagon or trailer the size of tire which is to be used on the vehicle will determine the load which can be hauled. Where a trailer is to be used extensively, oversized tires of good quality are recommended. Used automobile or truck tires are satisfactory for the limited amount of hauling that is done on many farms. Where used tires are placed on wagons the loads must be adjusted to the condition of the tires.

The following data will act as a guide for tire loads, based on maximum loads for tires that are in good condition and which are used at speeds not exceeding 16 miles per hour:

SIZE	PLY	TIRE PRESSURE POUNDS	MAXIMUM LOAD PER TIRE
<i>Truck tires</i>			
6.70 × 15	6	45	1360
7.00 × 15	6	45	1520
6.00 × 16	6	45	1255
7.00 × 17	6	45	1740
7.50 × 17	8	65	2440
7.50 × 18	8	65	2540
7.50 × 20	8	65	2740
8.25 × 20	10	70	3330
9.00 × 20	10	70	3960
7.00 × 16	6	45	1580
7.50 × 16	6	45	1815
<i>Implement tires</i>			
6.70 × 15	4	24	1185
7.60 × 15	4	24	1395
6.00 × 16	4	24	1130
7.50 × 16	4	20	1500
7.50 × 16	6	32	1970
<i>Car tires</i>			
6.00 × 13	4	24	725
6.50 × 13	4	24	835
7.00 × 13	4	24	920
6.50 × 14	4	24	890
7.00 × 14	4	24	980
7.50 × 14	4	24	1090
8.00 × 14	4	24	1180
8.50 × 14	4	24	1270
6.50 × 15	4	24	950
6.70 × 15	4	28	1120
7.00 × 15	4	28	1210
7.10 × 15	4	28	1210
7.60 × 15	4	28	1320
8.00 × 15	4	28	1400
8.20 × 15	4	24	1420

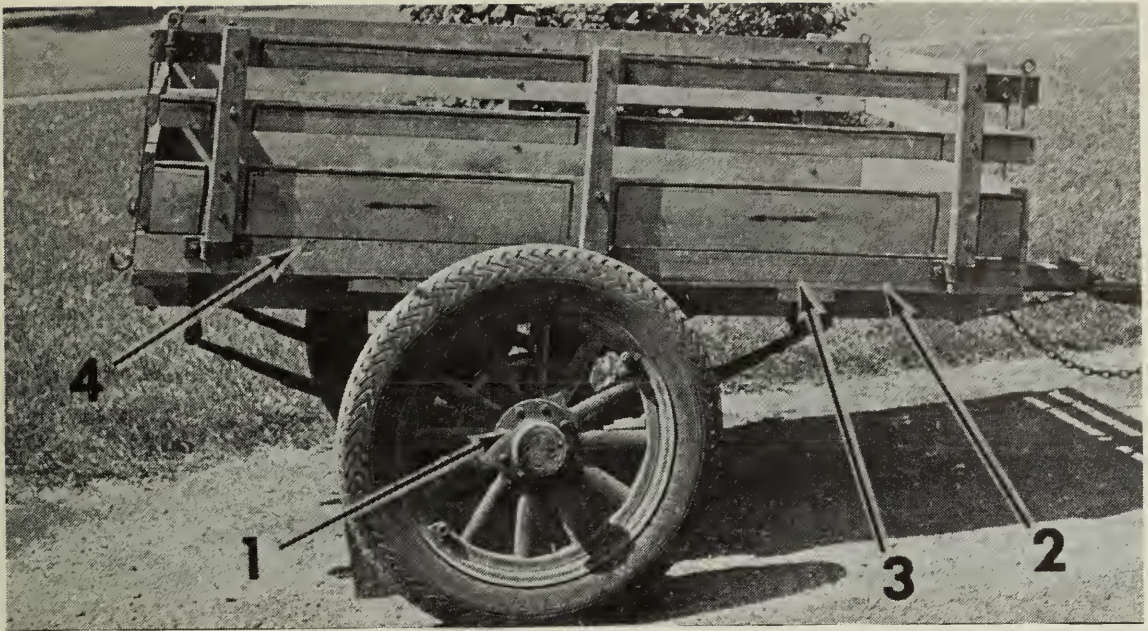

Figure 1—Small trailers or carts are suitable for many hauling operations. Trailers should be securely attached to the tractor or automobile. Note the use of safety chains between the cart and the vehicle.

Half Ton Trailers or Carts

Construction Details (See Figures 1 and 2)

A. Trailer with Removable Side Racks (See Figure 1)

(1) This half ton trailer or cart is mounted on a front end axle and wheel assembly from a light automobile. Commercial axles and wheels may also be used in the construction of light trailers and the unit can be assembled with or without springs. On trailers without springs low pressure tires are desirable to make the trailer ride more easily.

(2) The stringers which carry the body of the trailer are made from two $2'' \times 3'' \times 72''$ pieces of hardwood. These stringers are located directly over and in line with each spring so that they can be readily attached to the springs by shackles. As the springs are usually not parallel, the stringers are spaced further apart at the rear than at the front of the cart. The front shackles consist of two $\frac{1}{4}'' \times 3'' \times 4''$ plates with a steel bolt and a nut locked with a key. The upper bolt of the rear hinged shackle turns in a bronze bushing that is forced into a hole drilled in the stringer.

(3) Joists are made from three $1'' \times 5'' \times 44''$ hardwood boards placed on the flat and these joists are bolted to the top of the stringers. Tongue and groove material is used for flooring with the centre boards nailed to the joists and the two outside boards bolted to the joists.

(4) The edge pieces or stake pocket boards may be placed on top of the floor and joists, or below the joists if a clear flat platform is desired when the side racks are removed. Stake pockets made from $\frac{3}{16}'' \times 2''$

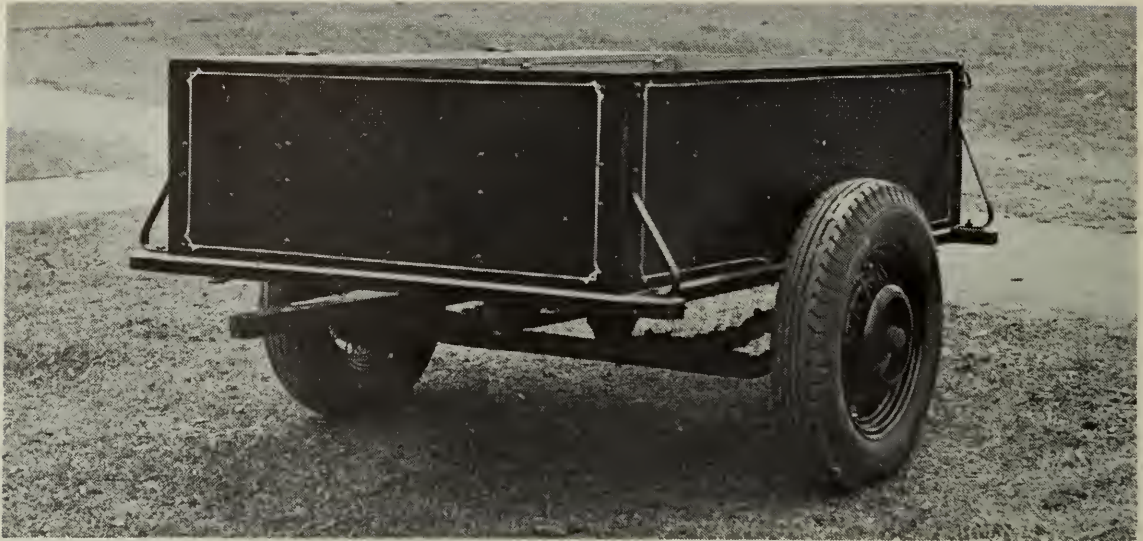

Figure 2—When automobile axles are used in making trailer carts the wheels should be kept in proper alignment. Wheels should toe-in slightly at the front.

iron are bolted to the 2" × 3" hardwood edge boards. Side racks on this trailer are usually about 16" high.

B. *Trailer or Cart with Solid Wall Box and Removable Tail Board*
(See Figure 2)

The cart illustrated in Figure 2 has an axle, spring and stringer assembly similar to the trailer illustrated in Figure 1. On both trailers or carts the springs and wheels are located slightly to the rear of the centre of the body so that the pole will rest on the ground when the trailer is uncoupled from a car or tractor. The body of the trailer is approximately 72 inches long and 46 inches wide. On the trailer shown in Figure 2 the edge pieces of the frame are mortised into the end pieces of the body frame. The pole is made of 2" × 5" × 72" hardwood tapered to 2" × 2½" at the front end with a tongue 19" long.

Figure 3—Trailers with a low platform or floor are desirable for some hauling operations. The floor on this trailer is only 20 inches from the ground.

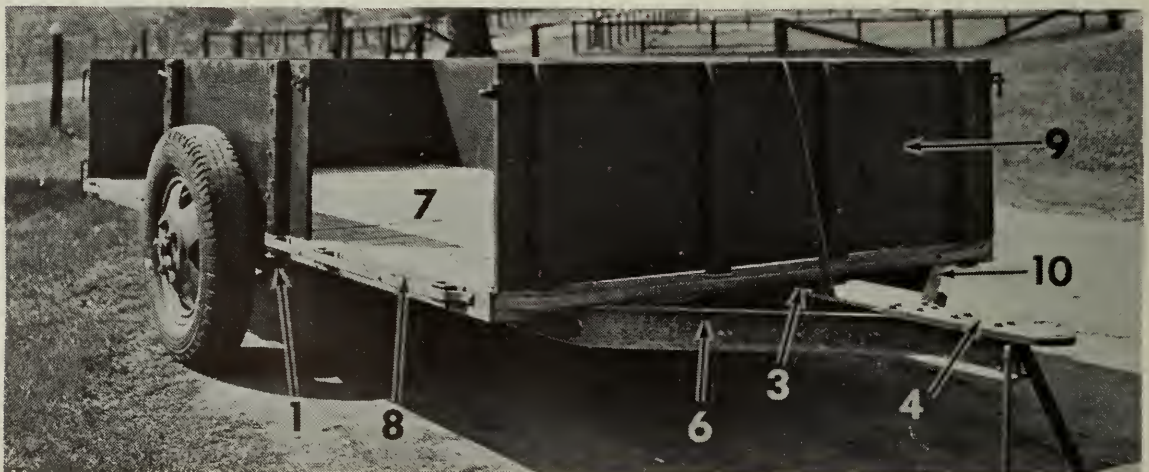

For use with small tractors a heavy piece of strap iron may be attached to the pole to form a draw bar plate. For use with automobiles, a sturdy and reliable ball and socket trailer hitch is essential so that the trailer can be securely attached to the automobile. Safety chains (See Figure 1) are compulsory trailer fittings in many districts. These chains are fitted to the trailer on either side of the pole and are separately attached to the automobile. On highways, trailers should be drawn at moderate speeds and every precaution should be taken to avoid accidents.

Wide Axle Trailer

Capacity 1½ Tons, Platform Size 6' × 13', Platform Height 20"

Construction Details and Materials (See Figures 3 and 4)

(1) Motor truck front axle cut and extended from 57" to 82", centre to centre of tire.

(2) Axle splicing assembly. Two channels $\frac{1}{4}" \times 1\frac{1}{2}" \times 3" \times 42"$ welded together along the flange edges from a close fitting box. Three steel bolts $\frac{1}{2}" \times 3\frac{1}{2}"$ run through this box and through each axle stub.

(3) Centre frame, channel iron $1\frac{1}{2}" \times 4" \times 15'$. The flanges are removed from 14" of this channel at one end and the wall of this portion of the channel is located between the outside channels where the three channels are connected together.

(4) Hitch plate $\frac{7}{8}" \times 5" \times 20"$ flat iron has 8" extending in front of the ends of the channels. The hitch plate is bolted to the outside channel flanges with six $\frac{3}{8}"$ bolts.

(5) Angle iron brackets. Two $2" \times \frac{1}{4}" \times 6"$ pieces of angle iron are bolted to the outside channels and to the axle through the spring clamp holes. The side frame channels are also bolted directly to the axle through the other pair of spring clamp holes. (See Figure 4).

(6) Outer frame channels. Two channel irons 17' long have a straight section below the platform measuring 13' with the straight section at the

Figure 4—An axle can be extended to construct the low platform trailer as shown in Fig. 3.

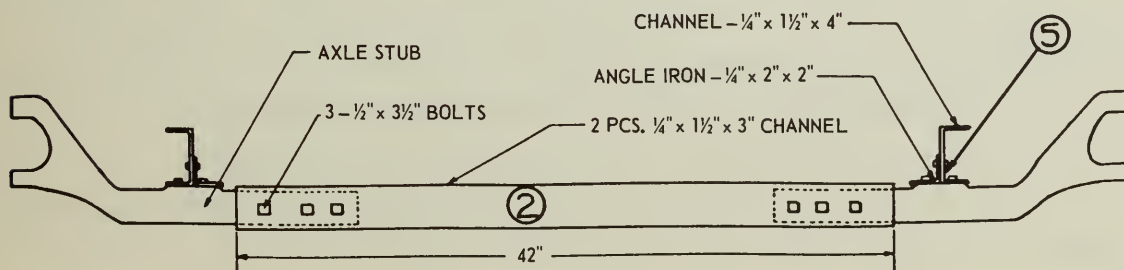

connection 12" long. These channels have their flanges turned towards the wheels. The distance from the centre to centre of the outside channels corresponds to the distance between the outside spring clamp holes on the axle after the axle assembly has been extended. This makes the channel spacing about 52".

(7) Platform. Plank floor 2" × 6" × 72" is bolted to outside channel flanges. A section ¼" deep and 1½" wide is cut out of the top of the floor planks at each end as a recess for the angle iron that carries the stake pockets.

(8) Edge angle for platform and stake pockets. These parts can be obtained from dismantled motor truck bodies or ¾" × 1½" × 1½" angle and cast steel stake pockets may be used. The 1¼" × 2½" stake pockets can be made up from ¼" × 1½" strap iron and bolted to the angle iron.

(9) Rack or Box Sections. The rack sections are made with one inch lumber bolted to hardwood stakes measuring 1¾" × 2½" and the sections are connected with hook and eye hardware fittings.

Steering tie rods are cut and welded to the axle with the wheels aligned and provided with ⅜ of an inch toe-in. (The measurement between the centre to centre of the tire tread at the front of the wheels should be ⅜ of an inch less than this measurement taken at the rear of the wheels.)

(10) Brake lever with cables connected to brake drums.

Transport Wagons

Capacity 3 Tons, Platform 6' × 12', Platform Height 14"

Construction Details and Materials (See Figures 5, 6 and 7)

(1) Ramp or side wall is attached to platform by four heavy blacksmith hinges.

(2) Side wall of box is made with three 2" × 10" planks which are fastened together with three 1" × 6" hardwood boards (7) and hinge straps (6).

(3) Bolts hold the long heavy hinge straps (6) to outside of side wall or ramp.

(4) The platform is 12' long between the wheels and 6' wide. The floor consisting of 2" × 10" × 72" planks is bolted to railway irons (28).

(5) Heavy blacksmith hinge butts are made from two pieces of ¾" × 1½" × 10" strap iron with an eye formed for the hinge pin.

(6) Four hinge straps are used on each side-wall ramp.

(7) Four cleats 1" × 6" × 26" are bolted to each of the side-wall planks.

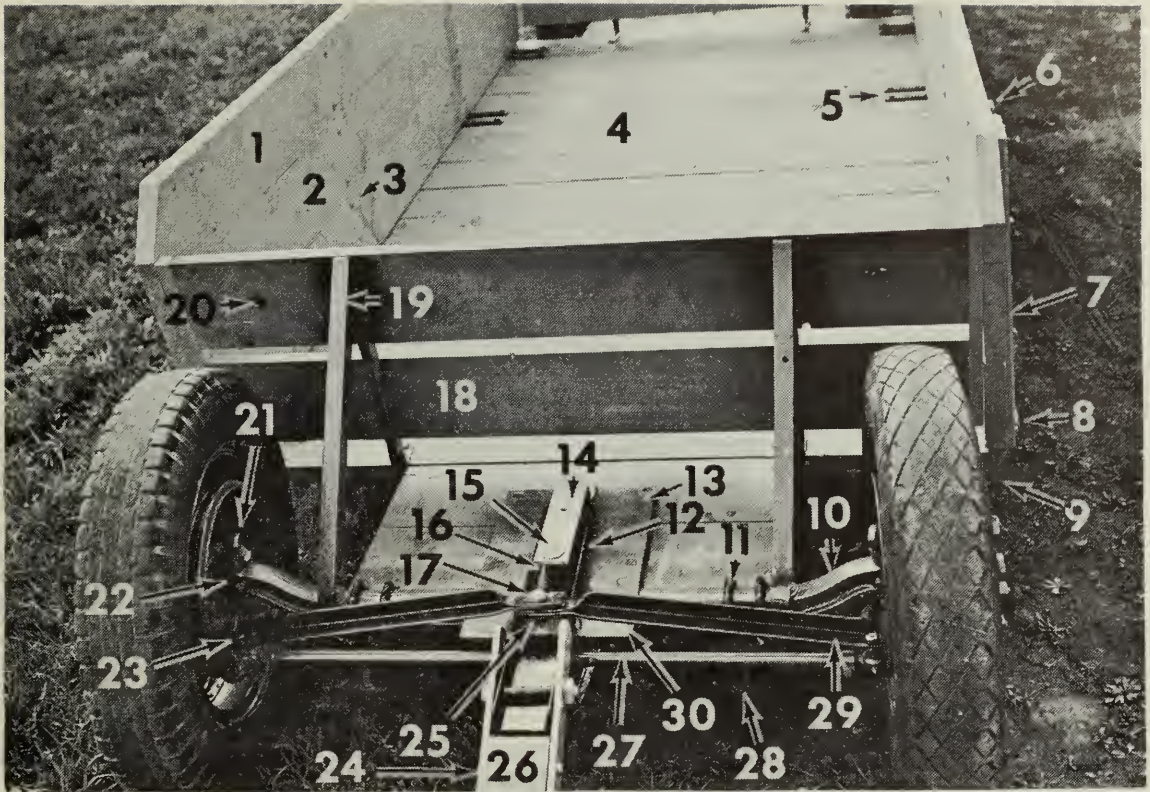

Figure 5—Construction details for the transport wagon illustrated in Figures 6 and 7.

(8) The hinge pin is a $\frac{3}{8}$ " bolt.

(9) Cleat planks $2'' \times 7'' \times 12'$ are bolted to the ends of the platform planks (4).

(10) Axle and wheels are front axle assemblies from a $1\frac{1}{2}$ -to-2-ton motor truck.

(11) U-bolts are placed over the axle and through holes in the base of the railway iron stringers. Eight $\frac{5}{8}$ " U-bolts are required.

(12) Steering arm consists of a piece of channel $\frac{3}{16}'' \times 1\frac{1}{2}'' \times 4'' \times 26''$.

(13) Steering plate is attached to platform with countersunk bolts. The plate measures $\frac{3}{16}'' \times 13'' \times 20''$.

(14) The hammer strap, $\frac{5}{16}'' \times 2'' \times 16''$, is fastened to plate (13) with a double bend to support draw bolt (15).

(15) Draw bolt, $\frac{5}{8}'' \times 6\frac{1}{2}''$ long, with nut and key.

(16) Spacer pipe for the draw bolt is welded to steering arm (12).

(17) Steering arm centre bolt, $\frac{3}{8}'' \times 1\frac{3}{4}''$ with nut and key.

(18) End boards, $1'' \times 10'' \times 68''$.

(19) Angle iron frame supports the end boards.

(20) Eye bolts for blacksmith hooks hold up side walls.

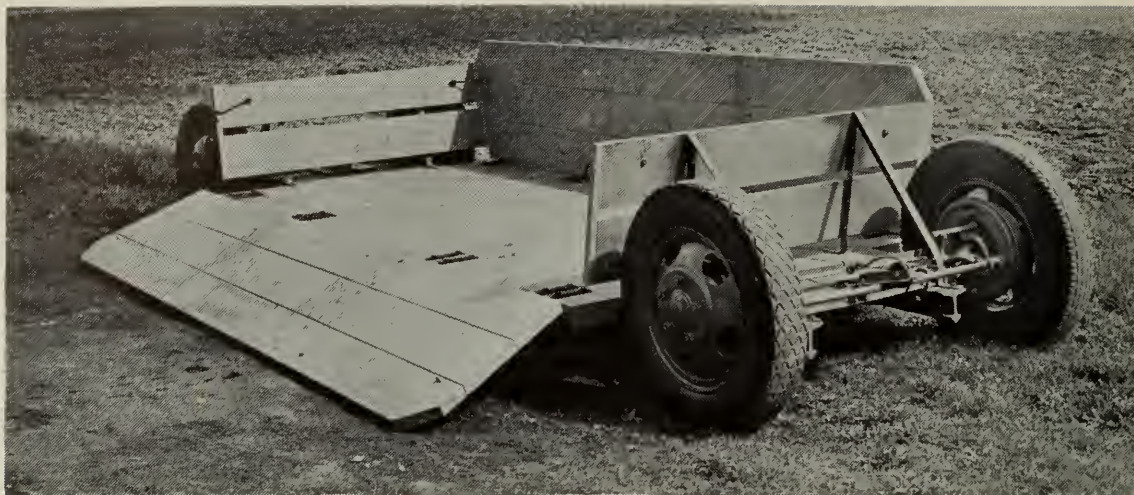

Figure 6—Side walls of the low transport wagon are hinged to form ramps for loading equipment or supplies.

(21) Front brakes removed, rear wheel brakes may be placed on this wagon.

(22) King pin centre.

(23) Cross link bolt. Distance from draw bolt (15) to centre bolt (17) is to be the same as from pin (22) to bolt (23).

(24) Side straps on the wood pole are two pieces of metal $\frac{1}{2}'' \times 2\frac{1}{4}'' \times 26''$.

(25) U-shaped strap, $\frac{5}{16}'' \times 1\frac{1}{2}'' \times 8''$ carries the centre bolt (17).

(26) Pole, $3'' \times 4''$ hardwood.

(27) Cross steering link. Shorten this link to give wheels a toe-in of $\frac{3}{8}$ of an inch.

Figure 7—Light tractors can be driven across the transport wagon in loading equipment onto this low wagon.



(28) Railway iron stringers are $14\frac{1}{2}$ feet long and weigh about 65 to 75 pounds per yard. These railway rails are placed upside down below the axle and they are fastened to the axle by U-bolts. I-beams 5" deep can be used in place of the railway rails in which case a piece is cut out of the web of the I-beam for a distance of $4\frac{1}{2}$ " at each end of the beams. By this means the axle is set into the end of the beam with the upper flange resting on top of the axle. A bolt is then used, placed through the two flanges of the beam in front of the axle, to tie the two flanges together again.

Two-Wheel Tractor Trailer

Capacity 2 Tons with Light Frame and Tires, 4 Tons with Heavy Frame

Construction Details and Materials (See Figures 8 and 9)

(1) Platform size 7'-6" \times 14'.

(2) Joist beams, $\frac{1}{4}$ " \times 3" \times $1\frac{1}{2}$ " channel or two $\frac{1}{4}$ " \times $1\frac{1}{4}$ " \times $1\frac{1}{4}$ " angles welded to form a box frame for a 4-ton trailer. For a 2-ton trailer, joist beams may be two $\frac{3}{16}$ " \times 1" \times 1" angles welded to form a box frame or 3" \times 4" hardwood may be used.

(3) Main frame beams should consist of $\frac{1}{4}$ " \times 6" \times 2" channels on 4-ton trailer or $\frac{1}{4}$ " \times 5" \times 2" channels for 2-ton trailer. For a light weight trailer with a capacity of 1 to 2 tons a $\frac{1}{4}$ " \times $1\frac{1}{2}$ " \times 4" channel may be used in making the frame.

(4) Chairs between the axle and the frame may consist of pieces of channel that are welded and strapped to the frame. Angle irons $\frac{1}{4}$ " \times $1\frac{1}{4}$ " \times 8" are welded to the bottom of the chair on either side of the axle to hold the axle in line. Four half-inch U-bolts are used to fasten the axle to the frame.

Figure 8—Heavy duty trailers may be used to advantage on the farm.

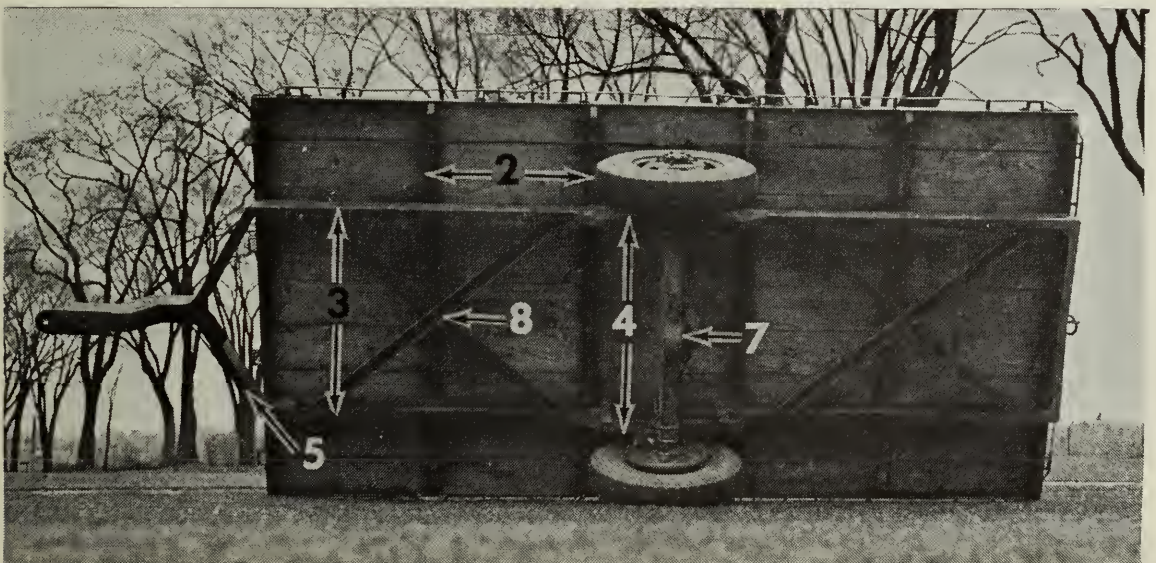



Figure 9—For heavy loads the trailer frame and platform should be sturdily constructed.

(5) To bend the channel frame at the end of the platform a V-shaped piece is cut out of each flange of the channel. The web of the channel may be heated with an acetylene torch to make the bend. The frame is welded together again after the bend is made. A $\frac{1}{4}$ " \times 6" plate is welded into the channel at the bend to give it extra strength.

(6) At the end of the pole the channels come together with the flanges of the two channels facing one another. To bend the channels at this point the flanges are cut, the web is heated and bent and a V-shaped piece is then welded into each flange. The flanges of the channels are welded together to form a box type pole section. A goose-neck can be made in the pole piece by cutting and welding operations to give the pole the required new position. The hitch plate consists of a piece of flat iron, $\frac{5}{8}$ " \times 5" \times 10 $\frac{1}{2}$ ", bolted to the bottom of the box type pole.

(7) The axle assembly is selected according to the load capacity of the trailer. For a 4-ton trailer a rear axle with dual wheels from a 3-ton motor truck may be used. For a 2-ton trailer select an axle from a 1 $\frac{1}{2}$ - or 2-ton motor truck with single wheels. (Refer also to section on load capacities for various sizes of tires.) For light trailers with a capacity of 1 to 1 $\frac{1}{2}$ tons the rear axle from a heavy automobile can be used. It is preferable to obtain full-floating rear axles so that the crown gear assembly can be removed. Square shaft axles with bearings, hubs and wheels can also be obtained in various capacities for trailer construction from hardware merchants and implement dealers.

(8) Two pieces of channel iron or suitable material may be fitted into the frame to make it more rigid.

For details on the construction of the platform and stake pocket assembly refer to the section on building a Combination Wagon Rack.

Rubber Tired Farm Wagon

Capacity 3 Tons, Wheel base 10

Construction Details and Materials (See Figure 10)

(1) Front and rear axle assemblies are axles from used cars or trucks. Axles from trucks are usually preferred as they have a clearance of about 10" under the axle.

(2) A front axle plate made from $\frac{1}{4}$ " \times 4" \times 34" strap iron is drilled at the ends so that it can be bolted to the axle through the inside spring saddle holes. Exactly on the centre line between the wheels, another pair of $\frac{5}{8}$ " holes are drilled through this plate for the bolts which fasten on the reach.

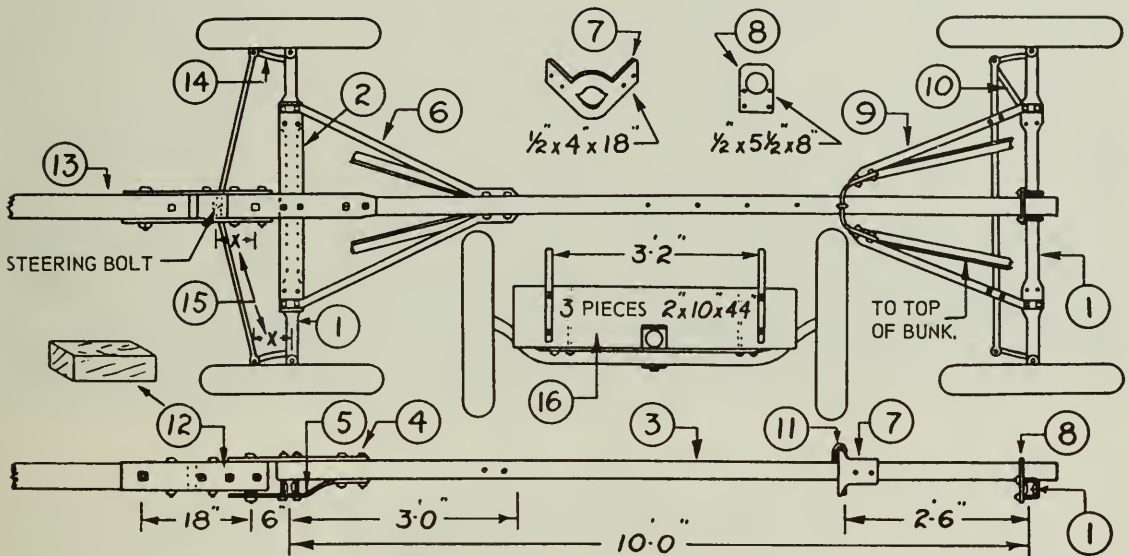

Figure 10—A complete rubber tired wagon chassis can be constructed in the farm shop. It often is preferable, however, to purchase a commercial wagon.

(3) Pipe measuring 2 or 2½ inches is used for the reach. A hardwood plug is driven into the front end of the pipe and the $\frac{5}{8}$ " bolt holes are drilled squarely through this end of the pipe.

(4) The upper drawbar plate made from a piece of $\frac{1}{2}$ " \times 4" \times 24" strap iron is drilled on the centre line for the two $\frac{5}{8}$ " axle bolts, for the two $\frac{1}{2}$ " lower draw plate bolts, and for the $\frac{3}{4}$ " king bolt.

(5) Lower draw plate, $\frac{1}{2}$ " \times 4" \times 25" iron is bent as shown in the attached drawing. Lock washers are used when bolting together the various parts.

(6) Radius rods or front braces are made from two 1½" angle irons. Make certain that the axles are at right angles to the reach pipe when fitting on the braces.

(7) A rear radius rod yoke with a split hole for the reach is formed as shown in the attached drawing. This type of yoke which can turn easily on the reach allows the rear axle to move freely when going over rough land.

(8) The rear axle reach guide plate is clamped to the rear axle with two clevis bolts.

(9) Rear radius rods are made from $\frac{1}{4}'' \times 1\frac{1}{2}'' \times 34''$ angle irons.

(10) A brace iron as well as clevis bolts are used to lock the rear steering link. Align the rear wheels before attaching this brace.

(11) A reach pin is formed from a piece of $\frac{1}{2}''$ rod with a U-shaped end that hooks over the radius rod yoke.

(12) The steering block is made from a piece of $4'' \times 4'' \times 12''$ hardwood with a guide plate of $\frac{1}{2}'' \times 4'' \times 24''$ iron bolted to each side, and with a $\frac{1}{4}'' \times 4'' \times 12''$ wear plate screwed to the top and bottom.

(13) Hardwood measuring $4'' \times 4''$ is used for the pole and it is protected on the sides with $\frac{1}{16}''$ wear plates. A $\frac{3}{4}''$ draw bolt with nut and key is used to attach the pole to the steering block guide plates.

(14) The spindle steering arms should be bent towards the wheels so that the tie-rod bolt hole is in line with the outer edge of the king pins. This improves the steering of the wagon.

(15) The distance from the draw bolt to the steering bolt (\times) should be the same as the distance from the axle king pin to the spindle steering arm bolt hole which holds the tie rod. (X).

(16) Each bunk is made up from 3 pieces of $2'' \times 10'' \times 44''$ plank bolted together and four $\frac{3}{8}'' \times 11''$ bolts through the bunk and spring saddle hold the bunk in place. Rear bunk stakes are 38'' apart. For sharp turning the rack frame should be tapered to fit between stakes that are 36'' apart on the front bunk.

Combination Wagon Rack With Steel Frame

**Flat Rack, Silage Rack and Hay Rack—Capacity 3-4 Tons, Platform Size
7' \times 14' or 16', Platform Height 38''**

Construction Details and Materials (See Figures 11 and 12)

(1) The stringers as shown on the rack in the accompanying illustrations are $\frac{1}{4}'' \times 4'' \times 1\frac{5}{8}''$ channel irons with channel iron headers welded to the stringers. The spacing of the stringers should be 28'' in the front, 40'' in the rear, on the outside of the channels. Flanges of the channel are facing towards one another.

(2) Chairs 2 to 4 inches high are welded to the bottom of the stringers, depending on the wheel clearance required. The bolster stop blocks which are attached to the rear chair are $\frac{1}{4}$ " \times 1" \times 4" angle iron.

(3) Joist may consist of $\frac{3}{16}$ " \times $1\frac{3}{8}$ " \times 3" \times 84" channel irons, or double $\frac{3}{16}$ " \times 1" \times 1" angle irons welded together to form a box. Metal joists, spaced about 28" apart, are bolted to the stringers with $\frac{1}{4}$ " or $\frac{5}{16}$ " bolts. Adjust joist spacing so that they are not directly over the wheels.

(4) Planks, 2 inches thick are bolted to the joist to form the platform.



Figure 11—Bottom view of a combination rack showing steel stringers and cross joint.

(5) Angle irons, $\frac{1}{4}$ " \times $1\frac{1}{2}$ " \times $1\frac{1}{2}$ " are bolted to the platform on all four sides to carry the stake pockets. A strip $\frac{1}{4}$ " deep and $1\frac{1}{2}$ " wide is cut out of the planks along the edge so that the top of the angle iron is flush with the surface of the platform. Angle irons with stake pockets can be obtained

Figure 12—A combination rack having a flat platform and fitted with stake pockets may be used with various low or high side wall box sections according to materials being hauled in the wagon.

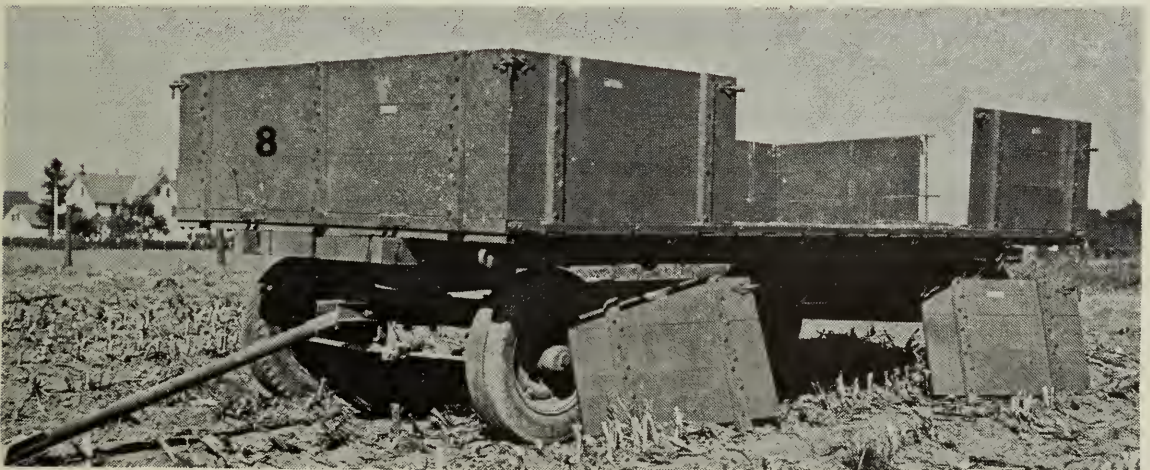

from discarded motor truck bodies or angle irons and stake pockets can be purchased from hardware dealers. Pockets can also be made from 1½-inch strap iron and bolted to the angle irons. In some cases small stake pockets are not used on the ends of the racks as the 2' × 7' box ends can be carried by hooks at the corners of the side rack walls or sections.

(6) Heavy stake pockets measuring 4" × 2½" × 3" may be placed on the ends of the racks, opposite or above the stringers, to accommodate 2½" × 3¼" × 6'-6" stakes for hauling loose hay. Cut the stakes to 2⅜" × 2⅞" at the ends to fit the pockets.

(7) With a pair of hooks underneath the rack, the horse or tractor pole can be carried at all times.

(8) Box sections 24" to 36" high are made from one-inch lumber bolted to 1½" × 2½" × 24" or 36" hardwood stakes. Hook and eye motor truck hardware fittings are used to hold the side panels together at the top. Three or four sections are made for each side and one 7-foot section for each end.

(9) For metal stringers, joists and edge piece irons the following materials are required: two ¼" × 4" × 1⅝" × 14' and two ¼" × 4" × 1⅝" × 2'-4" channel irons, seven ⅜" × 1⅜" × 3" × 7' light joist channel irons, two ¼" × 1½" × 1½" × 7' and two ¼" × 1½" × 1½" × 14' angle irons. The total weight of the channels and angles is about 420 pounds, which at 12 cents per pound would cost approximately \$50. Other hardware consists of 19 stake pockets, eleven pairs of hooks and eyes and assorted bolts and nuts.

Wisconsin Wagon Rack

Flat Rack, Silage Rack and Hay Rack—Capacity 3-4 Tons, Platform Height 38", Platform Size 7' × 14' or 16'

Construction Details and Materials (See Figures 13 and 14)

(1) The stringers as shown in the drawing are 4" × 6" × 14' hardwood or Douglas fir. Stringers may be built up of two 2" × 6" × 14' bolted together. The spacing of the stringers will be governed by the length of the wagon bolster on which the rack will be used.

(2) Cross braces 2" × 4" × 42" should be bolted under the stringers at each end with ½" × 12" bolts which also secure the front and rear joists.

(3) Bolster stop blocks are bolted to the stringers and fit the rear bolster. An angle iron 4" × 4" × ¼" × 12' with angle iron stop blocks of 2" × 2" × ⅜" × 4" welded to it will decrease wear on the stringer. Two pieces of 2" × 4" × 8" hardwood may be bolted to the stringer in place of the angle iron.

(4) The joists are made of 4" × 4" hardwood or Douglas fir. They are placed in front of the stake pockets and are set to give ¼" clearance from the stake pocket. The rear joist should be behind the stake pocket as shown in the diagram. Joists may be 2" × 4" spaced 2' on centres. Care must be taken to adjust the joists so that they do not interfere with stake pockets and so that, if possible, a joist is not directly over a wheel.

(5) The platform should be 2" plank bolted to the joists.

(6) Stake pockets may be made by cutting notches in a 2" × 6" × 14' to fit 2" × 4" stakes. The end pockets should be 4" from each end to give clearance for the joists. The three pockets between the end pockets should be evenly spaced 3'-4" on centres when building the 14' rack. The pockets are formed by bolting a 2" × 2" × 14' rail on the edge of the notched plank. Bolts should be placed 4" from centre of each stake pocket. Two bolts are required for each pocket to ensure a sturdy rack.

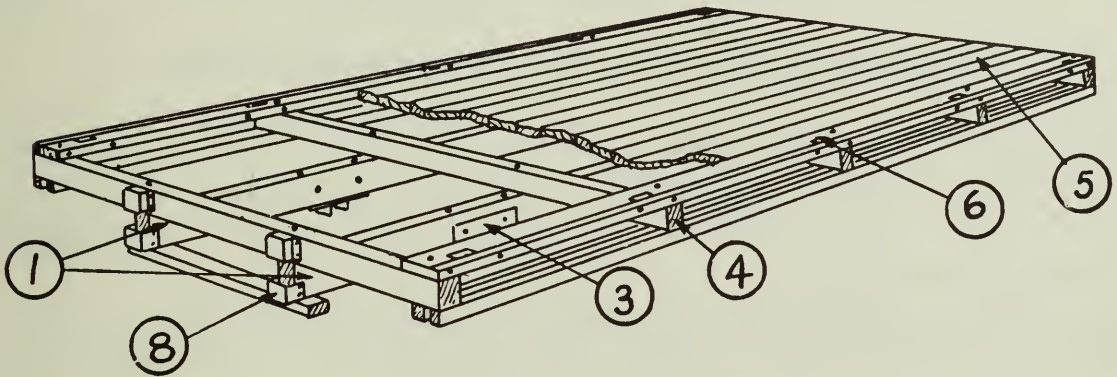

Figure 13—The Wisconsin combination rack is similar to the steel frame combination wagon rack but the frame is of wood construction.

(7) Stake braces 2" × 2" × 14' should be placed 2" apart under the joist and bolted in place. The bolts also fasten the stake and pocket rail assembly to the joists. The stake braces should be plumb with the stake pocket to ensure a straight sideboard.

(8) Metal stake pockets may be purchased to attach end stakes for hauling loose hay. The pockets should be bolted to the front and rear of the joist and to the stringer as shown in the diagram. The stakes should be at least 2" × 4" hardwood and the stake pockets must not be much smaller as cutting them down to fit the pockets weakens the stakes.

(9) Racks 24" to 36" high are made of one-inch lumber bolted to 2" × 4" stakes which extend beyond the stake braces at least an inch. The end sections should have a 2" × 4" cleat on each end to make them rigid as shown in the diagram.

The rack may be made having 3 or 4 sections on each side and one on each end. To accommodate these racks additional stake pockets must be made suitable for the racks.

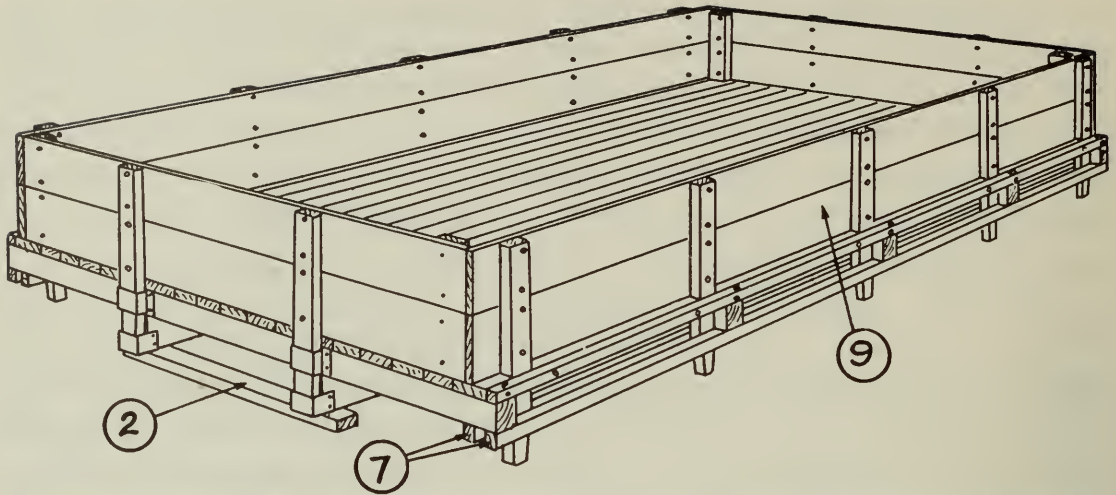

Figure 14—Box or side wall sections are fitted with stakes so that they can be removed from the rack. Side wall sections may range in height from 2 feet to 5 feet.

Chopped Hay Box for Combination Rack

Construction Details (See Figure 15)

When harvesting chopped hay in the field it was found necessary to have a large capacity side rack. The following side rack was developed to be used for this purpose.

(1) The side racks are constructed of softwood boards bolted horizontally to vertical hardwood stakes. The boards, 1" \times 4", are spaced 1½" apart with the exception of a 12" solid board at the bottom of the side rack. There are two side sections and a single section for each end.

Figure 15—A special box or side sections on a rack are desirable for chopped hay when using the wagon with a forage crop harvester.

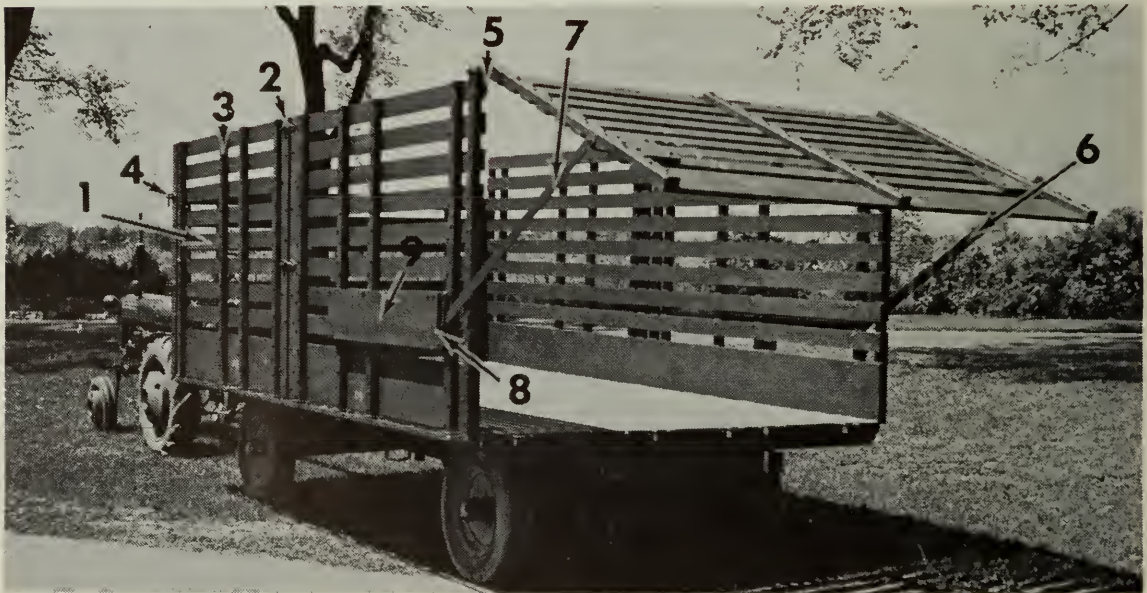

(2) Cleat boards, 1" × 4", are bolted to the ends of each section to make the rack rigid.

(3) Hardwood stakes, 1 $\frac{3}{4}$ " × 2 $\frac{1}{2}$ " × 64", are reduced at the bottom to 2 $\frac{1}{2}$ " × 1 $\frac{1}{4}$ " to fit the stake pockets.

(4) The front section is 1' lower than the side sections to accommodate the delivery pipe of a forage harvester.

(5) The rear section is hung on a $\frac{3}{4}$ " pipe which is supported at each end by the side sections of the rack. The stakes in the rear section of the rack are cut off to allow the section to swing open.

(6) The catch assembly for the rear section consists of a flat iron bar $\frac{5}{16}$ " × 2" × 54" attached 18" from the bottom of the rear section.

(7) A notch in the lower edge of the iron bar near the outer end provides a means of holding the rear section open. A similar notch holds the end gate in a closed position.

(8) A bolt, which acts as a catch for the notched bar, is held in position by a piece of iron $\frac{5}{16}$ " × 1 $\frac{1}{4}$ " × 6" fastened to the rear stake on the side sections of the rack. The bolt should be located approximately 18" above the platform, so that the notched bar is horizontal when the rear section is closed.

(9) A board 1" × 12" × 52" is placed over the bar to keep it in position when the rear section is closed. Spacers placed between the board and the stakes allow free movement of the bar.

Canvas Wagon Unloader

Specifications for a 7' × 14' Wagon Rack

Construction Details (See Figure 16)

(a) The canvas consists of eight pieces of No. 6 eighteen-ounce water-proofed canvas 30" wide and 78" long, sewn together with a double seam to form a 6 $\frac{1}{2}$ ' × 20' sheet. Seams should run crosswise of the wagon in the sheet and not lengthwise or bulges will form on the roller. Where available 6' × 20' single seamless canvas sheet can be used.

(b) A shaft or roller consists of a piece of heavy duty 2" pipe 7'-2" long. A plate 3" in diameter is welded onto each end of the pipe. Welded to each is a square shaft $\frac{5}{16}$ " × $\frac{5}{16}$ " which is 4" long. This square shaft will fit into a standard universal of a regular tractor power take-off unit.

(c) To fasten the canvas to the pipe, holes about $\frac{1}{8}$ " in diameter are drilled in the pipe at 6" intervals. Marine glue is brushed onto the pipe and the canvas is then tightly wrapped onto the pipe for two complete turns.



Figure 16—A canvas in the bottom of the rack can be used for unloading silage. A speed reduction unit is necessary to drive the canvas at the proper rate.

Metal or automobile upholstery screws of a suitable size are put through the canvas into the pipe. Roofing nails can also be used if the holes are just slightly smaller than the nails.

(d) Bearings for the pipe consist of two pieces of iron and an oiled hardwood block. The lower part of the bearing also forms the mounting arm to the wagon box and may consist of a piece of channel iron 2' long or a piece of 3" \times 3" two feet long. To form the bearing a hardwood block 3" wide 4" long and 2½" thick is placed on top of the mounting arm and is located 4" from the rear end of this arm. A plate 7" long ¼" thick and 3" wide is placed on top of the bearing block and bolted through the block into the mounting arm. This top bearing plate should be at the same level as the top of the wagon box platform. The bearing is thus a U-shaped device, in which the pipe is placed. A light pin put in through the end of the U-bearing section keeps the roller in place.

(e) A power take-off assembly is used between the gear reduction box and the roller. For deep loads the roller should turn 3 revolutions per minute and for shallow loads the roller may turn about 6 r.p.m.

(f) By giving the canvas a lap or fold about 2 feet wide at the centre of the box, the rear part of the load will begin to move off separately and then the front half will start. This reduces the strain on the canvas.

(g) A hand ratchet device may be used on the end of the roller for loads of less than 1,500 pounds and where there is a limited amount of material to be handled. In general, however, a power unit is desirable.

Speed Reduction Unit for Canvas Unloader

Construction Details (See Figure 17)

(1) The frame is constructed of 2" × 4" hardwood, using iron brackets and $\frac{5}{16}$ " bolts to ensure a rigid assembly. The frame is 24" wide, 60" long and 30" high. However, the height should be governed by the height of the wagon racks to be used with the unit, as better results are obtained when the drive shaft is horizontal.

(2) The ratchet wheel, 9 $\frac{1}{4}$ " in diameter with 40 teeth, is part of a manure spreader. It is keyed on a 1 $\frac{1}{4}$ " round shaft which is square at one end to provide for the attachment of the drive shaft. It should be advisable to have the shaft square at both ends, as this would make it possible to operate from either side.

Figure 17—A home-made reduction unit can be made for driving a canvas unloader using a manure spreader ratchet wheel.

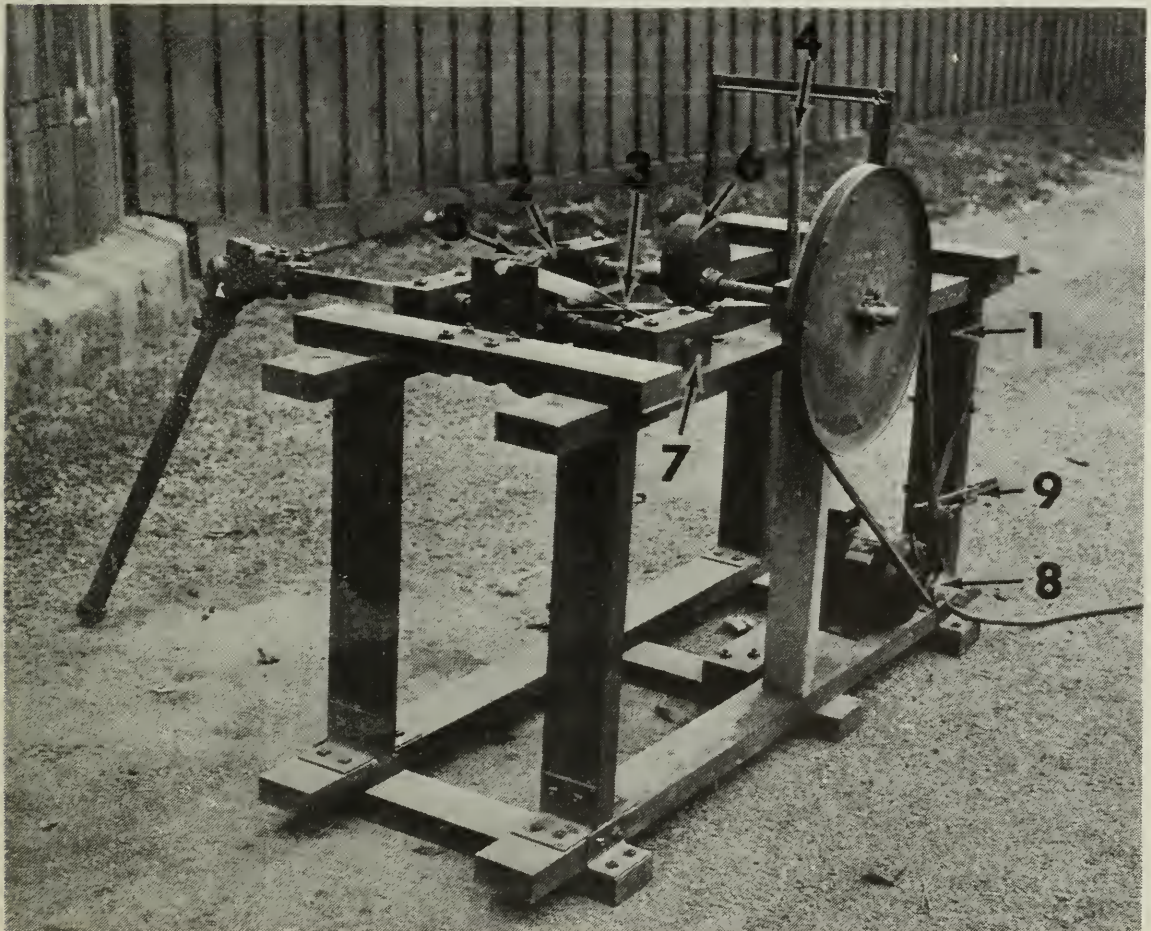

(3) The reciprocating pawl is mounted between two irons, $\frac{1}{4}'' \times 2'' \times 15''$, which are bolted on either side of the hardwood ratchet arm $2'' \times 2'' \times 24''$. This pawl mechanism is mounted on the ratchet shaft with the irons on either side of the ratchet wheel.

(4) A coil spring, $\frac{7}{8}''$ in diameter, 16'' long, made from $\frac{1}{8}''$ diameter wire, which draws the ratchet arm upward on the return movement of the eccentric wheel, is attached to an angle iron bracket, $\frac{3}{16}'' \times 1'' \times 1''$, 13 inches above the frame.

(5) The stationary pawl is mounted between two angle irons, $\frac{1}{8}'' \times 1\frac{1}{2}'' \times 1\frac{1}{2}'' \times 6\frac{1}{4}''$, attached to the frame and braced to ensure rigidity. Performance was improved by using two staggered stationary pawls which reduced the back lash to one-half of that encountered when using a single stationary pawl.

(6) An eccentric wheel is used to actuate the ratchet arm. This wheel consists of a circular piece of hardwood, 6'' in diameter, mounted between two $\frac{3}{8}''$ iron plates. Two 1'' collars are welded to the plates and two set screws lock the wheel to the shaft which passes through it. To give the necessary action the centre of the wheel is offset $1\frac{1}{2}''$ from the centre of the driveshaft. This produces a movement of 3'' per revolution. The distance between the ratchet wheel shaft and the eccentric wheel shaft would be $16\frac{1}{4}''$.

(7) The bearings are made of hardwood blocks $2\frac{1}{2}'' \times 3'' \times 6''$, which are drilled to accommodate the $1\frac{1}{4}''$ diameter shaft.

(8) The drive pulley on the $\frac{1}{2}$ h.p. motor is a 3'' "V" sheave, which drives the 18'' "V" sheave on the eccentric shaft.

(9) The belt tightener, which consists of an iron bar, $\frac{3}{16}'' \times 1\frac{1}{4}'' \times 10''$, connected to a slotted iron bar, $\frac{1}{4}'' \times 1\frac{1}{4}'' \times 20''$, is mounted on the frame. The slot is $\frac{1}{2}'' \times 12''$ and allows the idler pulley to be adjusted.

CAL/BCA OTTAWA K1A 0C5

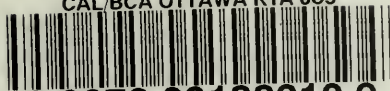

3 9073 00188310 9

First printed 1950
Revised 1951, 1959
Reprinted 1963
Reprinted (with some deletions)..... 1966

Copies of this publication may be obtained from:

INFORMATION DIVISION
CANADA DEPARTMENT OF AGRICULTURE
OTTAWA